



2015

# Downtown Overlay District Design Standards

EXHIBIT A

Downtown Overlay District  
Design Standards

Version:

---

*This document was formally adopted by the Wasilla City Council on \_\_\_\_\_.*

*Contact the City of Wasilla Planning Department for more information or to determine if there are additional updates available or pending. The version of this document is listed in the upper right hand corner by date.*

EXHIBIT A

Downtown Overlay District  
Design Standards

Version:

Table of Contents

**1 Corridor Standards (Roads and Streets) .....5**  
A. Corridor Classifications..... 5  
B. Corridor Design Requirements ..... 7  
C. Typical Corridor Sections ..... 8

**2 Site Design Standards .....10**  
A. Lots, Access, Setbacks and Building Orientation .....10  
B. Site Distance ..... 12  
C. Street Furnishings Zone ..... 12  
D. Outdoor Dining ..... 13  
E. Drive-Through Service Facilities ..... 13  
F. Fueling Stations .....13  
G. Sidewalks and Pedestrian Crossings ..... 13  
H. Parking Standards ..... 20  
I. Rear Entries ..... 25  
J. Open Spaces – Greenspace ..... 25

**3 Site Amenities ..... 25**  
A. Service Areas and Loading Docks ..... 25  
B. Utilities and Mechanical Equipment ..... 26  
C. Refuse Collection Areas and Dumpsters ..... 27  
D. Site Furnishings ..... 28

**4 Landscaping ..... 32**  
A. Professional Design Requirements .....32  
B. Locally Proven, Hardy, Urban Plants .....32  
C. Public Safety Regarding Dangerous, Noxious and Invasive Plants .....32  
D. Sight Distances and Plants ..... 32  
E. Entry Landscaping ..... 33  
F. Frontage Landscape Requirements ..... 33  
G. Walls (not building walls), Columns and Piers ..... 33  
H. Fences ..... 33  
I. Parking Lot Landscaping ..... 33  
J. Plazas, terraces, patios and other paved areas ..... 35  
K. Fountains ..... 35  
L. Parking Deck Landscaping/Screening ..... 35  
M. Buffers ..... 36  
N. Street Trees ..... 36  
O. Approved Plant Lists ..... 37

**5 Lighting .....37**  
A. Lighting Standard Requirements ..... 37  
B. Streetlight Requirements ..... 38  
C. Store front Lighting ..... 38  
D. Parking lot lighting ..... 38  
E. Pedestrian/Sidewalk Lighting ..... 38  
F. Cut-Off Style Lighting requirements ..... 39

EXHIBIT A

Downtown Overlay District  
Design Standards

Version:

---

<b>6</b>	<b>Signage</b> .....	<b>40</b>
A.	General requirements for all Signage .....	40
B.	Sign Colors .....	40
C.	Sign Materials .....	41
D.	Lighting of Signs .....	41
E.	Digital Signs .....	41
F.	Directional Signage .....	41
G.	Prohibited Sign Types .....	41
H.	Wall Mounted Signs .....	41
I.	Awnings and Canopies .....	42
J.	Protruding Signs .....	42
K.	Window Signage .....	43
L.	Address and Unit Numbering .....	43
M.	Artwork Perceived as Signs .....	43
<b>7</b>	<b>Building Construction Standards</b> .....	<b>44</b>
A.	New Construction Standards for Buildings and Structures .....	44
B.	Standards for Existing Buildings .....	53
<b>8</b>	<b>Sustainable Maintenance Requirements</b> .....	<b>54</b>
A.	All properties vacant or otherwise .....	54
B.	Vacant, cleared and undeveloped lots .....	55
C.	Maintenance Standards for All Developed Property in the Overlay District .....	55
	<b>Appendix A – Downtown Overlay District Map</b> .....	<b>57</b>

## EXHIBIT A

### Downtown Overlay District Design Standards

Version:

#### Downtown Overlay District Design Standards – Including All Sub-Districts

The major goal of these design standards is to ensure that the future development of land in the Downtown Overlay District will conform to the design, direction, and intent of the Wasilla Comprehensive Plan and the Wasilla Downtown Area Plan. These standards will help to guarantee that the developments occurring within the district are sited and built to standards that will support this vision and foster smart, pedestrian friendly and sustainable growth. The City's hope is that through these standards, a level of quality and a distinct personality will arise, setting Wasilla out from surrounding areas and ensuring it maintains wide ranging appeal among residents, businesses, and visitors alike.

Therefore, the purpose and intent of this document is to protect, enhance, preserve, or reuse places, sites, buildings, structures, objects, streets, signs, street furniture, sidewalks, and landscape features; provide for aesthetic, economic, and functional value of properties, and structures; and address issues of traffic, traffic operations and congestion, transit, bicycle and pedestrian access and safety, aesthetics of the built environment, business viability, and public safety in the Wasilla Downtown Overlay District (hereinafter may also be referred to as the "DOD"). The scope of this Article includes standards for sidewalks; pedestrian and site lighting; street trees; site development; design, materials, location, size, and orientation of buildings and accessory structures; landscaping; screening and materials; and signs. These standards are necessary to implement the goals contained in the Wasilla Comprehensive Plan and the Wasilla Downtown Area Plan. Such goals include, but are not limited to, implementing an integrated transportation and land use plan; creating a town center; applying design guidelines; improving traffic and the pedestrian environment, aesthetics of the built environment, and business viability; and promoting public safety. The Wasilla Downtown Overlay District Design Standards apply to all properties in the district. Land and structures shall be used in accordance with standards of the underlying zoning classification unless otherwise indicated in this Article.

This document contains design standards that apply to the development of public and private areas and for the creation of systems and amenities that are beneficial to the public, in the Downtown Overlay District. The design standards contained in this article are mandatory. **The instructions for application, enforcement, and interpretation of these standards are further discussed in Title 16 of the City of Wasilla Municipal Code.** Title 16 contains detailed definitions of as well as the description of the downtown overlay district and its boundaries. Within the downtown overlay district, the regulations set forth in this article shall be the minimum requirements and shall apply uniformly to each class or kind of building, structure or land.

**1 Corridor Standards (Roads and Streets)**

Each existing and proposed road in the Downtown Overlay District is designated as one of six (6) corridor types as follows: Avenues, Parkways, Boulevards, Main Streets, Urban, or Local Streets. Corridors are designated in Table 1 below.

The design standards related to the corridor designations have been established for each street type, and shall apply to all streets and street-side improvements contained in the Downtown Overlay District. Streets, sidewalks, parking, bicycle lanes, medians, and planting strips shall be installed consistent with the following standards and in Table 2 below:

Note: Standards for the number of travel lanes, travel lane width, shoulder width, bike lanes, allowance of on street parking, on street parking width, and the allowance of medians and access may be varied as required by the either the Alaska Department of Transportation or the Wasilla Public Works Director if it is determined that the standards provided here in do not meet future transportation needs and/or inhibit public safety.

**A. Corridor Classifications**

The following is a list containing the descriptions of the corridor typology to which all new and existing roads must be applied.

**(1) Avenues**

An Avenue is the largest and most visible street system in the Downtown Overlay District and is typically bordered by high density retail and commercial uses with many access points. Typically they have three (3) or more travel lanes in each direction. Avenues are the gateway streets of the City making them very important in establishing a sense of place.

**(2) Parkways**

Parkways are typically considered major thoroughfares for the City but have greater access control than avenues. They typically have two (2) to three (3) lanes in each direction. They typically will have wider medians with few breaks and include street trees and landscaping in the right-of-way and in the medians (if any).

**(3) Boulevards**

Boulevards are the next step down in size and traffic volume but are still considered significant collector roads and will typically have one (1) lane in each direction and may or may not have landscaped medians and right-of-way.

**(4) Main Streets**

Main streets are the main urban streets in the core areas of Downtown Wasilla and also the most decorative. They often will allow for and have on-street parking and adjacent sidewalks with street trees in planters and a street furniture zone. They may be one (1) or two (2) lanes in each direction and may or may not have medians.

**(5) Urban Streets**

These are smaller urban roads located in the Downtown Overlay District. They are typically single lanes in each direction or one (1) to two (2) lanes in one direction only. They typically have sidewalks directly adjacent to the back of curb and little or no planting strips other than street trees. They may also feature a street furnishings zone.

EXHIBIT A

Downtown Overlay District  
Design Standards

Version:

- (6) Alleys  
These are the smallest of the street classifications. They may provide access to parking areas for commercial buildings. They are usually not striped and composed of one large lane.
- (7) Street Corridor Designation Key

DOWNTOWN COMMERCIAL CENTER OVERLAY DISTRICT STREET		
<b>Avenues</b>		
<b>Street</b>	<b>From</b>	<b>To</b>
Parks Highway	Lucille	Yenlo
<b>Parkways</b>		
<b>Street</b>	<b>From</b>	<b>To</b>
n/a		
<b>Boulevards (No median)</b>		
<b>Street</b>	<b>From</b>	<b>To</b>
Bogard Road	Main	Yenlo
Nelson	Lucille	Main
<b>Main Streets (Protected bike lane)</b>		
<b>Street</b>	<b>From</b>	<b>To</b>
Yenlo	Parks Highway	Nelson/Bogard
Main	Parks Highway	Nelson/Bogard
Swanson	Lucille	Yenlo
Herning	Lucille	Yenlo
<b>Urban Streets</b>		
<b>Street</b>	<b>From</b>	<b>To</b>
E. Paulson (w. of Knik)	Parks	Nelson
Knik	Parks	Nelson
Lucille	Parks	Nelson
N. Boundary	Parks	Bogard
<b>Local Streets</b>		
<b>Street</b>	<b>From</b>	<b>To</b>
E. Paulson (e. of Knik)	Parks	Nelson
Willow	Parks	Swanson

Table 1 Street Corridor Designations

**B. Corridor Design Requirements**

The provisions of the City of Wasilla’s Municipal Code shall apply as minimum standards for all streets in the Downtown Overlay District except as noted in the following sections:

**(1) Alleys**

Alleys are encouraged and may serve both residential and commercial access and often are used for utilities corridors. They may not be designed to carrying two-way traffic at the same time. It is anticipated that not more than one vehicle would use the same alley at the same time.

- (a) Commercial alleys are restricted to one way traffic or to service and deliveries only.
- (b) An alley may not serve a parking lot unless it is one directional.
- (c) The entire alley should be visible from the entrance point. In situations where visibility cannot be provided, a section of the alley should be provided where passing of two vehicles would be possible.
- (d) All curves, turnouts, and radii for any edge of an alley shall conform to the minimum turning radii for a commercial garbage truck or a 36 foot triple axle vehicle. The minimum outside turning radii is 46.5 feet.
- (e) Garages, carports, loading docks, waste containment areas facing the alley must be spaced sufficiently far enough from the alley to provide access and parking. No structures’ face that has doors or openings requiring vehicular access shall be placed closer than 26’ from any alley’s edge of pavement.

**(2) Street Trees**

Street Trees are required along all roads in the Downtown Overlay District and shall be appropriately selected for urban locations and proximity to vehicular traffic. Care must be taken to select healthy, long lived and low maintenance species that are not known to be readily affected by ice and wind. Also trees that generally drop heavy crops of seeds, nuts or fruit are not suitable urban trees. See the landscape section of this document for additional requirements for street trees. The following are the approved species of trees for the major roads of the Downtown Overlay District:

Landscape and Street Tree Standards						
DESIGN ELEMENT	Species	Min Height	Min Caliper	Spacing	Planting Location of Street Trees	Min Planting Area
AVENUES	Must be approved by City Planner and Public Works Director.	Twelve (12) feet	Four (4) inches	50' max	Planting Strip	200 sf
PARKWAYS	Must be approved by City Planner and Public Works Director.	Twelve (12) feet	Four (4) inches	50' max	Planting Strip	200 sf
BOULEVARDS	Must be approved by City Planner and Public Works Director.	Twelve (12) feet	Four (4) inches	50' max	Planting Strip	200 sf
MAIN STREETS	Must be approved by City Planner and Public Works Director.	Twelve (12) feet	Three (3) inches	40' max	Furniture Zone	Four (4) by eight (8) feet (thirty two (32) square feet)
URBAN STREETS	Must be approved by City Planner and Public Works Director.	Twelve (12) feet	Two and one half (2.5) inches	40' max	Furniture Zone	Four (4) by eight (8) feet (thirty two (32) square feet)
LOCAL STREETS	Must be approved by City Planner and Public Works Director.	Twelve (12) feet	Two and one half (2.5) inches	50' max	Planting Strip	Five (5) by eight (8) feet (forty (40) square feet)

**Table 3 Street Tree Requirements by Corridor Type**



# EXHIBIT A

## Downtown Overlay District Design Standards

Version:

### C. Typical Corridor Sections

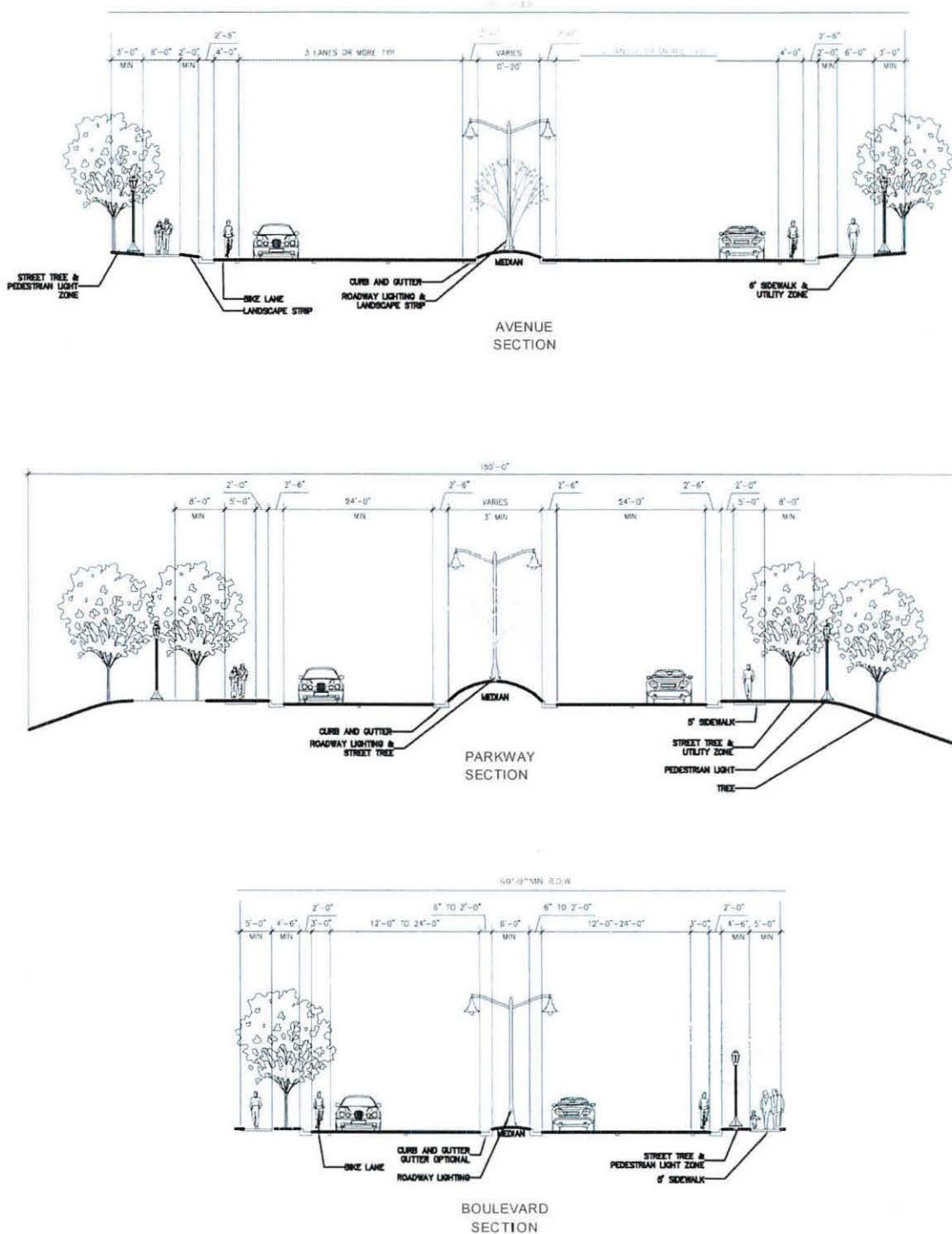

Figure 2 Typical Corridor Sections

# EXHIBIT A

## Downtown Overlay District Design Standards

Version

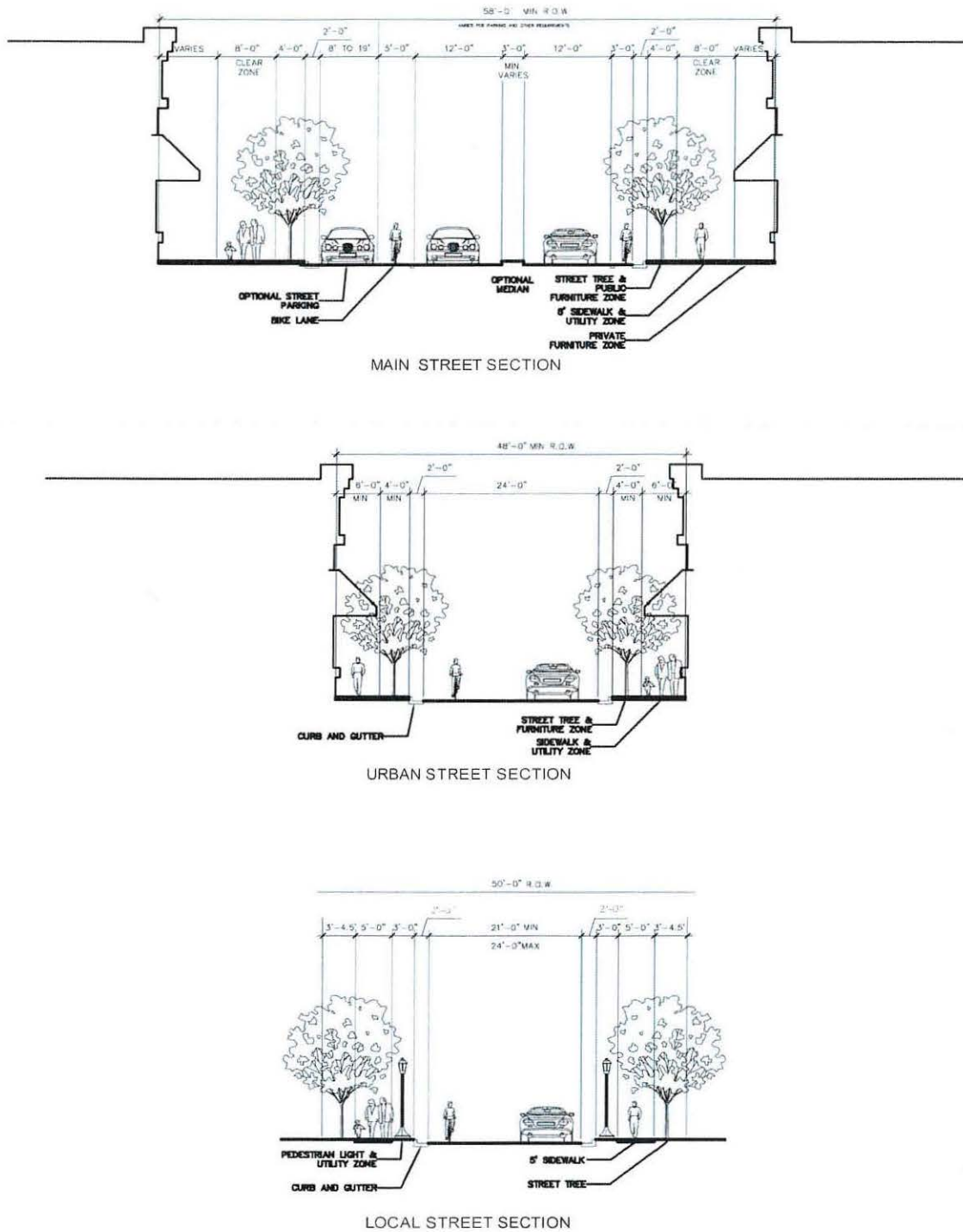

Figure 3 Typical Corridor Sections

**2 Site Design Standards**

Site design standards govern all of the major site elements from the face of the building to the back of curb. More particularly, they include the layout of the entrances, parking areas, drive isles, pedestrian connections, building locations and footprints, loading zones, detention areas, etc.

**A. Lots, Access, Setbacks and Building Orientation**

- (1) Lots - All new lots created in the Downtown Overlay District shall meet the minimum requirements in Title 16 of the City of Wasilla Municipal Code.
- (2) Access Management - Access management is the practice of properly locating and designing access to adjoining properties to reduce conflicts and improve safety while maintaining reasonable property access and traffic flow on the public street system.
  - (a) All parcels fronting Avenues, Parkways, Boulevards or Main Streets with parking lots shall be required to provide inter-parcel access to any adjacent property which also fronts the same street. The location, quantity, and size of the access are subject to the approval of the city Public Works Director and the City Planner and must meet the requirements in this section.
  - (b) Driveways and Curb Cuts unless otherwise stated shall meet the following minimum standards:
    - (i) Driveways and curb cuts are to be limited in both number and size to minimize conflicts between pedestrians and vehicles. Site plans shall separate curb-cuts to the greatest extent possible and must be approved by the Public Works Director and the City Planner.
    - (ii) Driveway curb cuts shall not be permitted on any street that functions as an arterial street or collector street when access may be provided from a side or rear street located immediately adjacent to a contiguous property.
    - (iii) No more than one curb cut shall be permitted for each development (except as noted below), provided that properties with more than one street frontage may have one curb cut located on each street. For the purposes of this section, two curb cuts serving two one-way driveways shall only be counted as one curb cut provided that each curb cut does not exceed 15 feet in width.
    - (iv) Developments on properties with a single street frontage greater than 400 feet shall be permitted two curb cuts along one street frontage.
    - (v) All curb cut locations are subject to intersection setbacks, deceleration lanes, sight distance and or other traffic engineering requirements as dictated by the AKDOT&PF and/or City Public Works Director.
    - (vi) Driveway curb cut widths shall be 24 feet for two-way entrances and 12 feet for one-way entrances, unless otherwise permitted by the City Public Works Director.
    - (vii) The City Public Works Director may authorize a common or joint driveway. A letter of agreement is required from both property owners stating their understanding and agreement with the proposed common driveway curb-cut. The letter of agreement must be recorded as a perpetual easement on the property.
    - (viii) All sidewalk-paving materials shall be continued across any intervening driveway at the same prevailing grade and cross slope as on the adjacent sidewalk clear zone and must meet Americans with Disabilities Act

## EXHIBIT A

### Downtown Overlay District Design Standards

Version: \_\_\_\_\_

requirements. This means that in circumstances where the property is below the street grade, the curb-cut may have to rise to the sidewalk grade before dropping to the site elevation. Exceptions may be made by the City Public Works Director in circumstances where grades are extreme.

- (3) **Setbacks and Build-To Lines/Zones**  
All yards or frontages adjacent to a public street shall have setbacks and or "build-to zones". "Build-to zones" require a building face to be constructed in a specified zone to ensure the appropriate scale is achieved for the streetscape.

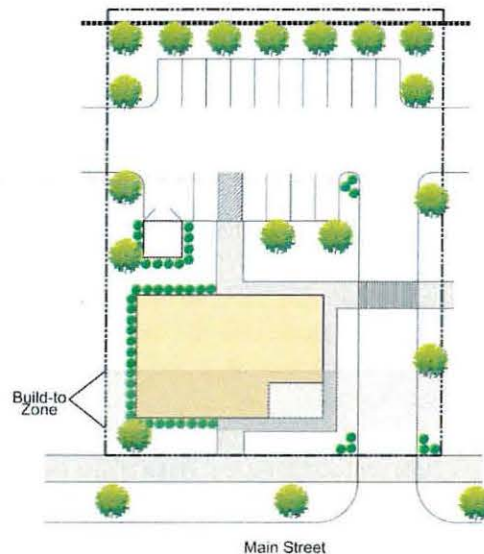

Figure 4 "Build to" Illustration

Except as noted below, the setbacks required for zoning shall apply.

- (a) On Main Street Corridors only, the Build-To Zone shall be from a minimum of 12' to a maximum of 24'.
- (b) Any building along a Main Street Corridor set back more than 15' shall only do so in order to accommodate outdoor space needed for plazas, dining, art, fountains, bicycle parking, gathering and seating places, gazebos, or similar uses. Such improvements shall be documented on the final site plan.
- (c) On Urban Street Corridors only, where there is not a parking lot or significant planned greenspace between the building and street, the Build-To Zone shall be a minimum of 10' and a maximum of 20'.
- (d) Minimum side yards: Except as noted above in (b), all side yard setbacks in these two sub-districts only, may be reduced to zero (0) feet as long as building code required fire walls and or minimum building separation is maintained.
- (4) **Orientation**
- (a) New buildings located on corner lots shall be placed adjacent to sidewalks on the two sides of the building that face the public right-of-way following the "build-to zone" established in (3) above.
- (b) In the event that a property shares a property line with either a Main Street or

EXHIBIT A

Downtown Overlay District  
Design Standards

Version:

Parkway Corridor, the primary face of a building shall front Main Street first and the Parkway second with the exception that buildings fronting a major public greenspace or park may orient the primary building face towards that greenspace. Administrative exceptions to this requirement may be granted by the Wasilla Planning Commission.

- (c) All buildings shall be placed in the most efficient position to screen large parking lots from public right-of-way.

**B. Site Distance**

No building, sign, structure or object, tree or other landscape feature shall be installed, built, or allowed to grow which will impede visibility at street corners, driveways and/or intersections, pursuant to AASHTO standards for minimum clear sight triangles.

**C. Street Furnishings Zone**

- (1) Clear Zone: Immediately adjacent to the shared landscape strip and street furnishings zone, there shall be a clear zone of 6' minimum for sidewalks where there shall be no permanent structures, including but not limited to, utility poles, mail boxes, newspaper vending boxes, sign structures, projections below 8', and benches.

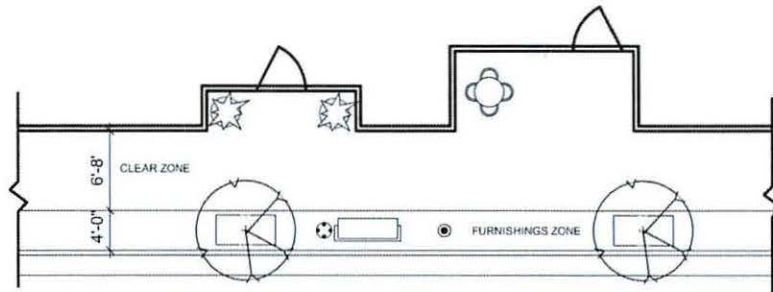

Figure 5 Clear Zone Diagram

- (2) Furniture Zone: The remaining portion of the sidewalk, outside the clear zone, may be used for the following purposes, including, but not limited to street trees, waste receptacles, bicycle racks, benches, and other seating elements that do not obstruct pedestrian access or motorist visibility.



Figure 6 Furniture Zone Example

**D. Outdoor Dining**

Small areas for patio seating (tables and chairs) placed on the public sidewalk, immediately adjacent to an indoor café or restaurant shall be permitted under the following conditions:

- (1) All furnishings must be kept outside the minimum clear zone for the sidewalk.
- (2) Any fencing used to separate the dining area shall be 34-36" in height and made of metal and painted appropriately to complement the architecture and adjacent furnishings. (Black is preferred.)
- (3) No waiting areas for patrons or customers shall be established where they shall block the access to adjacent buildings or sidewalks.
- (4) Furnishings for outdoor dining areas shall be subject to approval of the City Planner and should be designed appropriately to complement the streetscape. All furnishings shall be made of metal or wood components. Glass table tops are permitted. Plastic is not permitted.
- (5) Umbrellas in dining areas shall not protrude into any clear zone below 8' nor over a projected adjacent property line. Umbrellas may not include any logos, graphics or text other than a manufacturers label and must be solid colors.

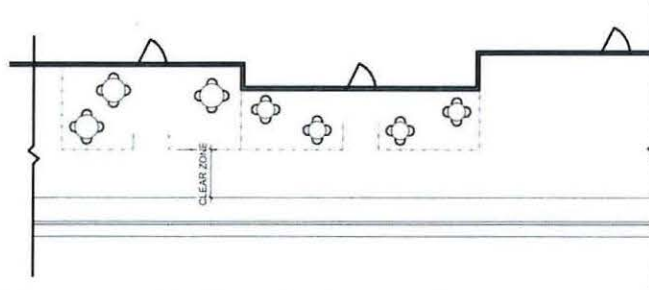

Figure 7 Outdoor Street Side Dining Examples



Figure 8 A-B Examples of Street Side dining separated by low fence

**E. Drive-Through Service Facilities**

- (1) Drive-through facilities are not permitted in the Downtown Overlay District except as authorized in the Use Chart in WMC 16.20.040.G.

**F. Fueling Stations**

- (1) Businesses that dispense gasoline fuel or similar products used to fuel automobiles including cars, trucks and motor bikes are prohibited in the Downtown Overlay District.

**G. Sidewalks and Pedestrian Crossings**

Sidewalks provide the connecting link between the buildings, amenities, and businesses in Downtown Wasilla. The designs, finishes and materials must remain consistent in order to tie the areas together. Around the downtown parks, in crosswalks, intersections, and at the entrances of

EXHIBIT A

Downtown Overlay District  
Design Standards

Version:

municipal buildings, the City of Wasilla has chosen to use decorative pavers, concrete, and/or asphalt to accent certain areas. Private developments can be visually linked to these facilities by using the same pavers in similar ways to unifying the downtown area for even greater impact.

- (1) Sidewalk Layout
  - (a) The minimum width for all sidewalks is 5'.
  - (b) Sidewalks widths shall remain constant in areas of similar use and scale but may taper as they cross into a new street classification with dissimilar usage.
  - (c) When possible, sidewalk width changes should occur at a new block, street, or driveway crossing so that tapering is not necessary.
- (2) Sidewalk Clear Zones
  - (a) Shall be the minimum width indicated in Table 4 below, located immediately contiguous to the landscape zone, and shall be continuous.
  - (b) Said clear zone shall be unobstructed for a minimum height of 8' except for temporary obstructions for public events such as those caused by the placement of carts, tables, tents, etc. for an arts festival or craft fair. Furnishings for private sidewalk sales may not obstruct the clear zone.

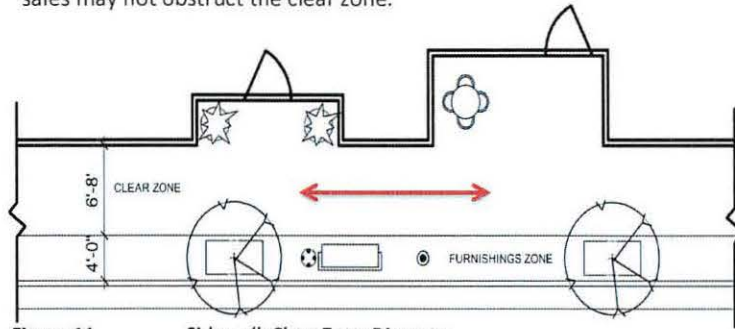

Figure 11 Sidewalk Clear Zone Diagram

- (3) Public Sidewalk Widths by Corridor
  - (a) For sidewalks constructed in the right-of-way for any of the road corridors, the following minimum widths and other requirements shall apply:

SIDEWALK REQUIREMENTS				
CORRIDOR	MIN. DISTANCE FROM BOC	PAVED FURNITURE ZONE AT BOC	SIDEWALK REQD BOTH SIDES	MIN. WIDTH OF SIDEWALK
AVENUES	2'	NA	Y	6'
PARKWAYS	2'	NA	Y	5'
BOULEVARDS	4.5	NA	Y	5'
MAIN STREETS	4'	4'	Y	8'
URBAN STREETS	4'	4'	Y	6'
LOCAL STREETS	3'	NA	Y	5'
ALLEYS	NA	NA	NA	NA

Table 4 Sidewalk Width and Other Requirements

BOC = Back of curb

EXHIBIT A

Downtown Overlay District  
Design Standards

Version:

- (b) The design and appearance of sidewalks shall remain consistent across a block or along a street between intersections and new developments shall match existing sidewalk designs with exceptions by approval of Wasilla Planning Commission.
  - (c) Sidewalk paths shall be continued across the entire length of all concrete aprons and shall match the appearance of sidewalk materials, in color, texture and design.
  - (d) Where rights-of-way are insufficient to accommodate the required sidewalk and planted strip, these elements may be located outside the right-of-way, if appropriate easements are granted to the City of Wasilla.
- (4) Sidewalk Ramps
- (a) ADA Ramps/Sidewalk Flaring – The Americans with Disabilities Act (ADA) requires ramps to transition the changes in grade from street pavement to sidewalk (typically 4-6 inches). All applicable ADA laws and guidelines apply to this ordinance.
  - (b) The use of truncated domes and similar tactile warning surfaces shall be limited to locations where the pedestrian is entering a regularly traveled vehicular zone, such as a street or heavily used site entrance. Truncated domes are not necessary at intersections of every curb-cut such as private residences. However in circumstances where a ramp and path intersect a heavily traveled entry to a business, the application of a tactile warning surface may be warranted.
  - (c) The following detail shall be employed at the intersections of streets and major drive isles for parking lots:

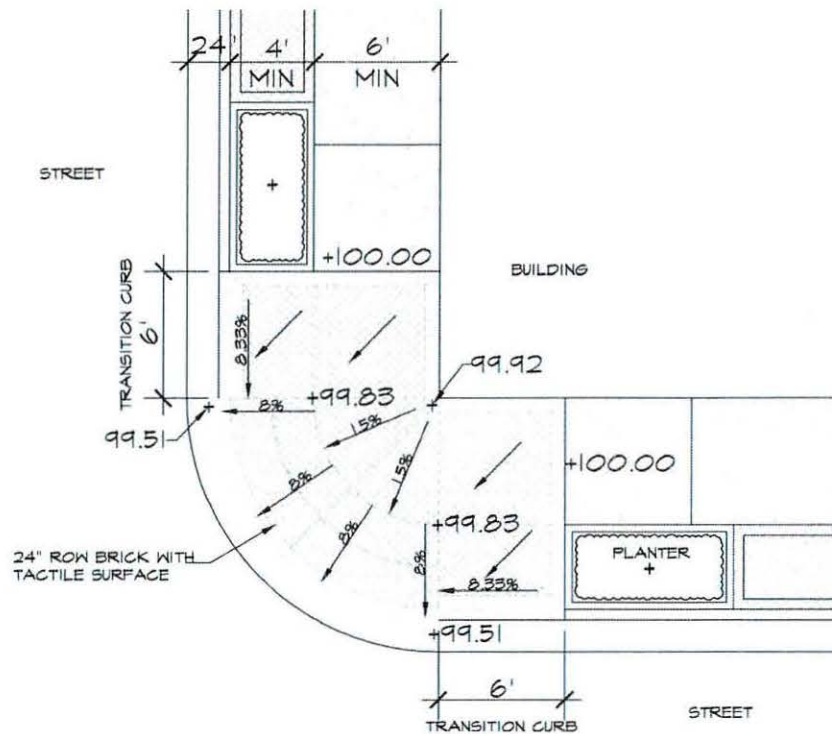

Figure 12 Typical Corner Ramping and Sidewalk Intersection Design



EXHIBIT A

Downtown Overlay District  
Design Standards

Version:

- (d) In locations where a sidewalk does not intersect another sidewalk, flaring or triangles shall not be used. Instead transitions in adjacent grade, additional ramps and curb returns shall be employed to avoid the necessity of flaring the sidewalk.

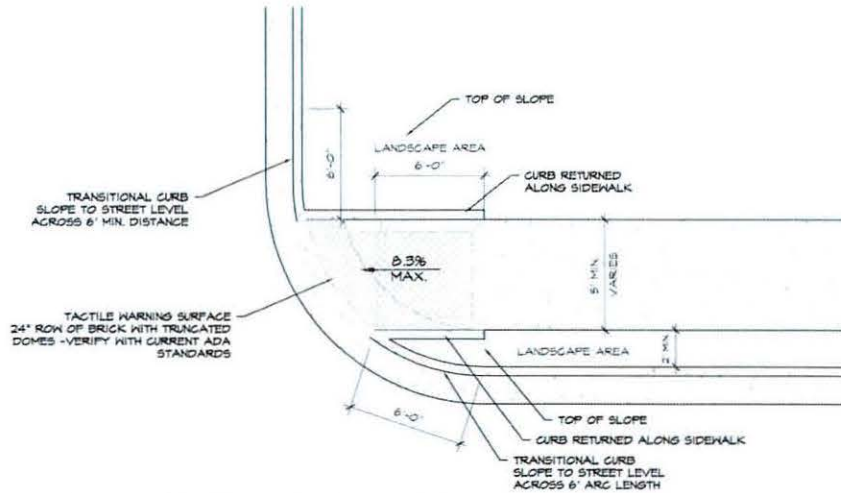

Figure 13 Typical Ramp Design with Turn-Back Curbs

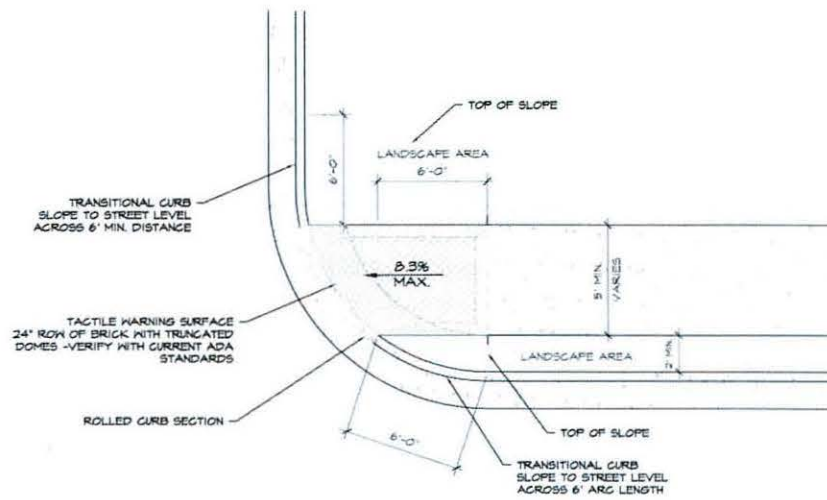

Figure 14 Typical Ramp Design Alternative w/out Turned Back Curbs

- (5) Crosswalks
  - (a) Crosswalks are to be prominently identified and each intersection's corner shall have handicap access ramps meeting all ADA requirements.
  - (b) Crosswalks are required at all road and street intersections.
  - (c) All crosswalks on Avenues and Parkway Corridors shall be designed per AKDOT&PF standard details with painted white striping.

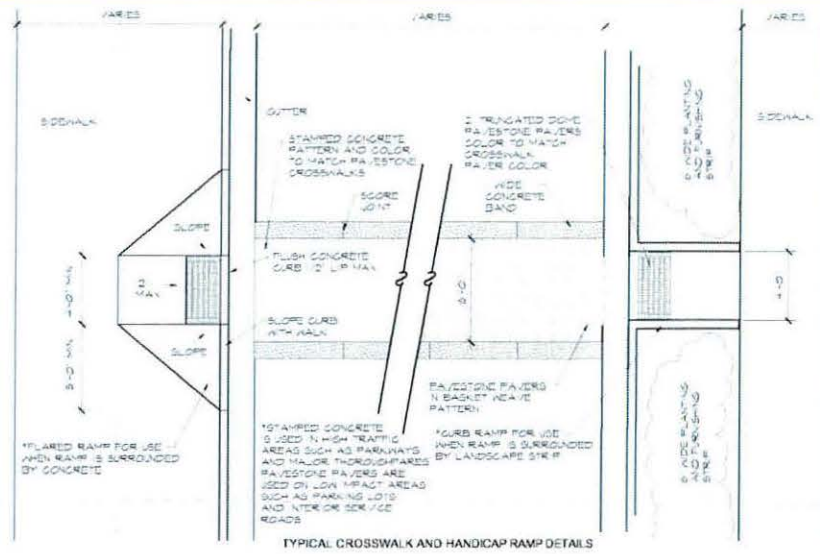

Figure 16 Standard Crosswalk Details

- (d) All crosswalks in Boulevard, Main Street and Urban Street Corridors shall be decorative and consistent in appearance with other decorative crosswalks in the overlay district.
- (e) When decorative crosswalks are called for, the type and colors of pavers to be used are specified by the City. Contact the Public Works Department for the specifications and local vendors.
- (6) Landscape zones
  - (a) Landscape Zones vary in width by corridor and shall be a minimum of 2' feet in width and located immediately adjacent to the back of curb (boc). There is no maximum width for a landscape zone.
  - (b) With the exception of interruptions for curb cuts and required utility crossings, all landscape zones shall be continuous except when interrupted by paved areas with intermittent planters of varying lengths.
  - (c) This zone may be used for street trees, streetlights, benches, planters, trash receptacles, bicycle parking racks and other street furniture, public utilities, pedestrian lights, landscaping, or sod.

EXHIBIT A

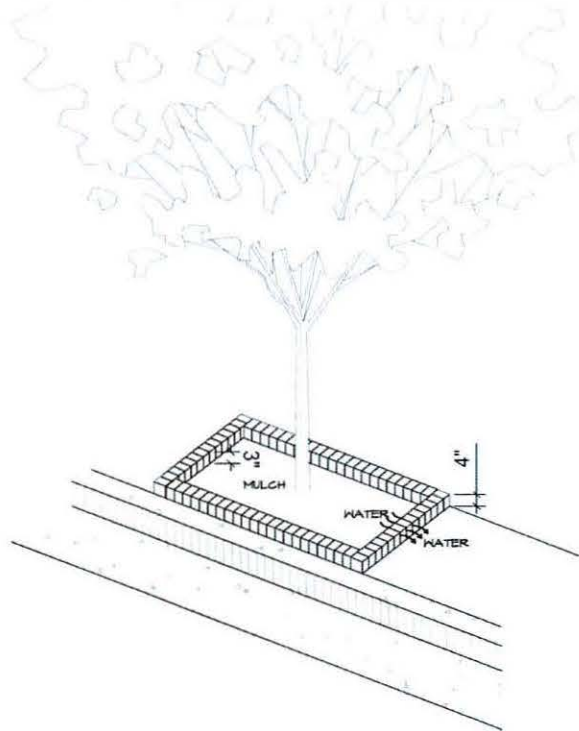

Figure 19 Standard Landscape Zone Treatment – Brick Edger

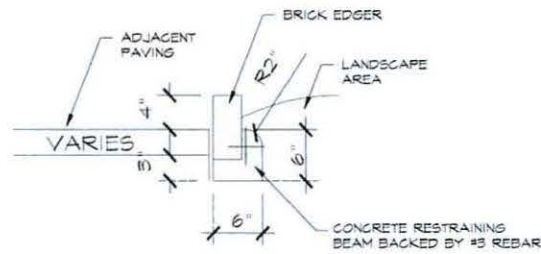

Figure 20 Detail of Brick Edger Installation

EXHIBIT A

Downtown Overlay District  
Design Standards

Version:

- (7) Intra-parcel Walkways
  - (a) A continuous, paved on-site intra-parcel walkway of at least 5' in width is required to connect the public sidewalk to the main entrance(s) of that property's building(s), and shall comply with the Americans with Disabilities Act (ADA), in all respects.
  - (b) Intra-parcel walkways crossing parking lots shall be distinguished from parking lots by the use of colors, texture, (use of different materials), difference in elevation above the parking lot or a combination of these means, in order to minimize auto-pedestrian conflict.



Figure 21 Inter-parcel walkway/sidewalk example

**H. Parking Standards**

Vehicle parking must respect the goal for a pedestrian-oriented and attractive downtown. Visitors and residents must feel safe walking to retail and office establishments without crossing multiple driveways. Visitors to the downtown should be able to park and then safely walk to several destinations.

**(1) Minimum Requirements**

- (a)** The design of all parking facilities shall comply with the appropriate provisions of Title 16 of the City of Wasilla Municipal Code and include the proper number of spaces per the proposed usage and density. The dimensional requirements required herein shall prevail over all others.
- (b)** Developments within the Downtown Overlay District are required to provide new off-street parking according to the following minimum standards:
  - (i)** The total number of permitted parking spaces shall not exceed 100 percent of the minimum number of off-street parking spaces required by type of permitted use.
  - (ii)** The minimum dimension for standard parking spaces is 9 feet by 18 feet.
  - (iii)** On-street parking may be permitted adjacent to the street curb with approval of the City Planner.

**(2) Shared or Reduced parking Standards**

- (a)** Reduction of parking requirements through a shared parking arrangement may be permissible only through the approval of the City Planner provided the arrangement shall avoid conflicting parking demands and provide for safe pedestrian circulation and access.
- (b)** A to-scale map indicating location of proposed parking spaces shall be provided.
- (c)** A shared parking calculation projection shall be provided that demonstrates that each use will have adequate parking provisions at all times.
- (d)** For contiguous properties sharing parking spaces under this provision, cross-easements shall be filed establishing access to the parking spaces in perpetuity.
- (e)** A reduction in the number of parking spaces that would otherwise be required for each of the various uses on a multiple-use property must be clearly shown on the development plan. If shared parking is proposed for a combination of contiguous properties, a plan must be submitted covering all of the properties that will be sharing the parking spaces.
- (f)** Location on other property: If the required automobile parking spaces cannot be reasonably provided on the same lot on which the principal use is conducted, such spaces may be provided on adjacent or nearby property, provided a major portion lies within 1,000 feet of the main entrance to the principal use for which such parking is provided, and measured by the most direct route of travel on the ground.
- (g)** Off-site parking requirements may be met on property owned by the developer or leased by the developer for a minimum of five years.
- (h)** A written agreement among all owners of record shall be provided and held on file with the City of Wasilla Planning Department. All renewed or terminated leases shall be filed with the Planning Department.
- (i)** If at any time the building owner fails to meet the required parking space requirements, the city via its staff can revoke the land use permit or business license.

# EXHIBIT A

## Downtown Overlay District Design Standards

Version:

- (3) On-Street Parking
- (a) On-Street Parking helps dense urban areas to create the small town feel and provide parking in very close proximity to businesses. On-street parking shall be permitted in the Downtown Overlay District.
  - (b) The number of on-street spaces allowed to be counted towards the parking requirements is subject to the approval of the City Planner and is typically restricted to spaces fronting the property lines.
  - (c) No 90 degree parking is permitted on the street
  - (d) Street side parking shall be parallel or angled parking.
  - (e) "Back-in" or "reverse-in" angled parking is encouraged along one way roads in lieu of standard angled parking.
  - (g) On-street parking design must comply with the standards in Table 5 below. Parking islands must be placed between grouped parking spaces. A tree is required in parking islands for all parking types except parallel parking spaces.

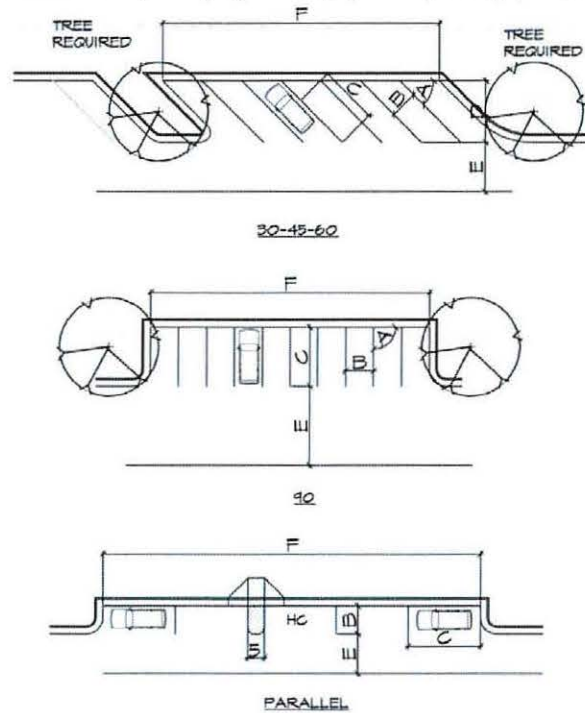

Figure 23 Typical Parking Layouts

Parking Requirements					
A	B	C	D	E	F
0	8'6"	22'*	N/A	12' MIN	5 SPACES
30	8'6"	18'	16'9"	15' MIN	7 SPACES
45	8'6"	18'	18'9"	15' MIN	8 SPACES
60	8'6"	18'	19'9"	16' MIN	9 SPACES
90	8'6"	18'	N/A	24' MIN	10 SPACES

Table 5  
Typical Layout Dimensions and Spacing of Islands

\*26' For Disabled Parking Spaces

## EXHIBIT A

### Downtown Overlay District Design Standards

Version:

- (4) Off-Street Parking
- Off-street parking must comply with the following parking bay, peninsula, and island dimensions and requirements:
- (a) Parking bays may be no wider than 66 feet and not less than 60 feet.
  - (b) Every two bays must be separated by at least a 10' wide planting strip (BOC to BOC).
  - (c) There shall be no more than ten (10) contiguous parking spaces before the spaces are interrupted by a tree planting island or peninsula.
  - (d) All sets of parking spaces shall begin and end with a 10' wide or greater landscaped island or peninsula.
  - (e) The width of any parking lot island or peninsula shall be a minimum of 10' (from BOC to BOC) and the depth shall be not less than 18' (from BOC). The radii of an island or peninsula shall be a minimum of 5'.

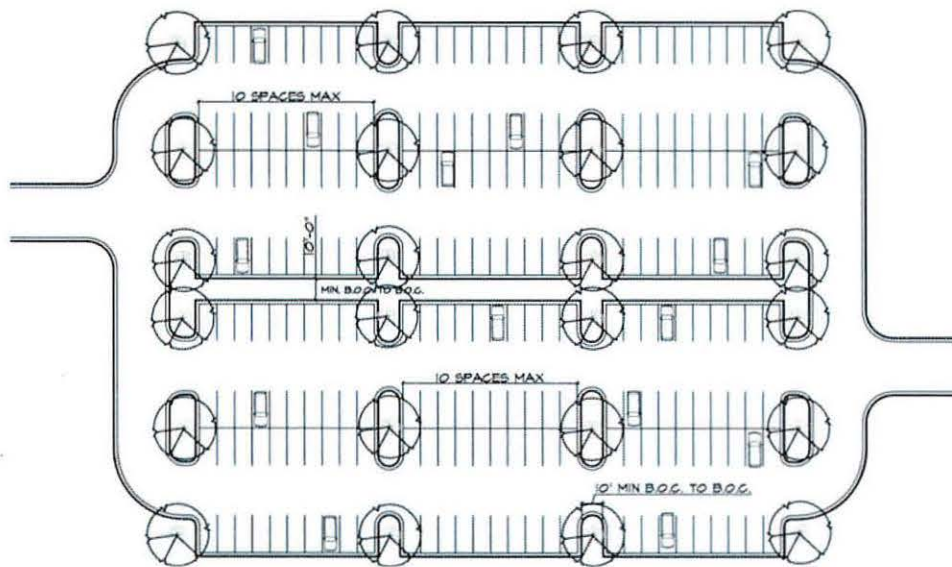

Figure 24 Typical Parking Lot Illustration

- (5) Parking on Vacant, cleared or undeveloped lots
- With the following exceptions, vacant, cleared or undeveloped lots may not be used to store or park vehicles unless a permanent parking lot has been established.
- (a) The City Planner may authorize the temporary storage or parking of vehicles for a temporary public or emergency event in the downtown area.
  - (b) The property owner may park one or more personal cars or vehicles as long as such vehicles are parked on pavement and screened from view from a public right-of-way. The owner must also be able to prove ownership for a vehicle to qualify for this exception and the vehicle must be operable and have a current registration.
- (6) Orientation
- The orientation of parking is dependent on several factors including the size of the parking lot, number of adjacent roads and use of the parking lot.
- (a) All parking shall be placed in the rear yard or behind an imaginary line projected from the primary front wall of the building or wall closest to and facing a public street.

EXHIBIT A

Downtown Overlay District  
Design Standards

Version:

- (b) When more than two bays will fit parallel to the building frontage, bays shall be turned perpendicular to the building face to improve pedestrian flow and to provide drop off and pick up locations in front of the building.



Figure 25 Parking Orientation to the Rear and Side

- (7) Screening
  - (a) Parking lots shall be screened from view from public rights-of-way as described in the landscaping section of these standards.
- (8) Inter-Parcel Access
  - (a) Inter-parcel access shall be provided between adjacent commercial developments to ease traffic congestion at choke points and provide for emergency access when one point of egress becomes blocked.
  - (b) Parking lots shall provide for future interconnectivity and inter-parcel access.



Figure 26 Illustration of Inter-parcel Access Requirements

- (9) Pedestrian Access
  - (a) All developments shall have sidewalks connecting ground level parking to the public sidewalks and to all building entrances.





**Figure 27** Illustration of Pedestrian Access Requirements

- (10) Pervious Parking and “Green” Parking Design
- (a) Parking Area Rain Gardens (Bio-retention): The use of bio-retention areas in the form of rain gardens and bio-swales in parking lots is encouraged.
- (11) Parking Decks
- Parking decks are permitted but must meet the following requirements:
- (a) Parking deck facades shall conceal automobiles from visibility from any public right-of-way, private drive, or street that is open to the general public, and shall have the appearance of a horizontal storied building.
- (b) Parking is not allowed within the first floor of parking garages within 30 feet of street-facing facades. The first floor street-facing facades should be used for tenant space with active uses.
- (c) All parking decks and parking structures shall have pedestrian walkways a minimum width of 6 feet connecting ground level parking to the public sidewalks and to all building entrances.
- (d) All parking decks and parking structures without first floor tenant space shall have a landscape strip with a minimum width of eight feet immediately contiguous to the parking facility for the whole of the exterior perimeter of the parking facility. See the landscape section for specific requirements.
- (e) When adjacent to a public street, above street level parking structures and decks shall create visual interest through the articulation of openings, cornice lines, and belt courses or similar architectural details.
- (f) Finishes for public frontage shall include architectural treatments and veneers such as brick, stone, faux windows, etc. Plain or colored concrete with or without simple textures will not meet the requirements. Grade level frontage shall be veneered in materials similar to surrounding buildings and appropriate for the downtown overlay district.
- (g) Alternatively a heavy and effective screen of landscaping may be approved by the Planning Commission.

**I. Rear Entries**

The rears of buildings often function as more than delivery areas. The rears of buildings will sometimes face the main parking area for customers and must provide a pleasant and well-kept appearance. A business may want an additional entrance from the rear of the store to reduce the walking distance for customers. The rear of the building may also be developed for shared parking and deliveries. The following standards apply to areas to the rear of the building:

- (1) Architectural and landscape elements from other parts of the building should be incorporated into the rear entrance.
- (2) Provide adequate lighting for customer safety.
- (3) Rear entrances for customer use shall mimic the primary front entrance.
- (4) If a rear customer entrance is provided, a smaller version of the main entrance sign may be used to denote the store's rear entrance.

**J. Open Spaces – Green Space**

Open spaces provide important health and social benefits to a downtown. Open spaces balance the built environment, and ensure adequate sunlight and air circulation within the downtown. Opportunities for alternative transportation and increased connectivity can be achieved when adjoining open spaces are connected. Open spaces create outdoor living rooms for community interaction, and provide areas for relaxation and/or recreation.

- (1) Open space shall be required for all development in the amount equivalent to a minimum of 20 percent of the total site area.
  - (a) Requirements for sidewalks and landscaping that are constructed on private property may be counted towards this requirement.
  - (b) Open space may also include planted areas, fountains, plazas, trails and paths.
  - (c) Hardscape elements related to sidewalks and pedestrian uses such as plazas which are located on private property may also be counted. However, no asphalt may be counted towards these requirements.
  - (d) Open space shall not include areas devoted to public or private vehicular access or parking nor to sections of sidewalks that cross parking areas or drive isles.
  - (e) All open space must be accessible to the public or to the occupants/users of the provided use. Open space counted towards meeting the requirements shall be prohibited from being inaccessible or not usable. Elements that are not physically accessible to the public or occupant/users such as large water fountains where bathing is not allowed, fenced utility and/or detention areas and similar elements are permitted but shall not be counted towards the total area of the open space.
  - (f) When adjacent to the open space of another property, open space shall connect to said adjacent open space and provide a fluid and direct connection to said open space. The connection of these spaces creates both corridors for people as well as animals.

**3 Site Amenities**

Site amenities include furnishings, equipment, refuse and loading areas. The careful selection, placement and/or screening and maintenance of these elements can significantly impact the aesthetic qualities of a development.

**A. Service Areas and Loading Docks**

- (1) Loading areas shall not face any public street.
- (2) All non-residential entrances, structures, and facilities for storage and loading shall be screened from view from the public right-of-way or pedestrian circulation area with one or

a combination of the following elements: continuous evergreen plantings, or other material related to the primary landscape or architectural elements on the site.

**B. Utilities and Mechanical Equipment**

The opportunity exists in downtown Wasilla to place all utility lines underground. Since the majority of downtown Wasilla will be new development including new sidewalks, utility lines can be placed underground prior to sidewalks being set in place. Utility lines such as phone, electrical and cable should be planned through agreements with the utility companies. Conduit for utility lines should be installed underground before buildings are built to avoid cutting streets and sidewalks at a later date.

**(1) Appearance**

Utilities almost always have a negative impact on the aesthetic value of a site. Therefore, care is to be taken in selecting equipment that has the least impact on the site. The smallest utility meters, valves, boxes etc. available that meet the requirements should be used and the colors or paint should be selected to blend into the surroundings. The body, conduit, and main pars of gas, electric and other utility meters located adjacent to or on building walls and visible to a public street shall be painted to match the buildings. For example a gas meter setting adjacent to a brick wall should be painted brick red.

**(2) Locations**

- (a)** All utility lines shall be placed underground.
- (b)** Utility meters such as gas and electric shall be placed on walls that do not face public streets or heavily used public areas. The City Planner may approve locations facing the street if they are screened.
- (c)** Back flow preventers, well pumps, check valves, and other devices that require above ground pipes, conduits, controllers, pressure tanks, housings, or similar features shall not be placed in locations where they are readily visible from the public right-of-way or public gathering areas.
- (d)** Utilities shall not be placed where they will interrupt sidewalks or clear zones.
- (e)** Utility locations shall be coordinated with the street trees and required landscaping so as not to interrupt the regular spacing required for trees, lighting or other landscape elements.

**(3) Screening Utilities**

In order to create a pleasant environment for the downtown visitor, adequate screening is required to minimize the negative visual and noise impacts of parking lots, storage areas, loading areas, and trash receptacle areas. Screening can be designed to enhance the downtown through the use of solid brick walls, latticework, trees, or shrubbery.

- (a)** Accessory mechanical systems and features, including air and heating systems on roofs, shall not be visible from the public right-of-way.
- (b)** All structures and facilities for outdoor equipment shall be screened from view from any street or pedestrian circulation area with architectural features and/or landscaping.
- (c)** When plantings are used as screens, such plantings shall be evergreen. Such plantings shall count toward required minimum landscape areas rather than being in addition thereto.
- (d)** Where walls or fences are used in lieu of planted screens, landscape materials shall be incorporated into the screening scheme whenever feasible.

EXHIBIT A

Downtown Overlay District  
Design Standards

Version:



Figure 31 Left – Poorly Planned and Unscreened – Not Permitted  
Right – Attempted Screening Desirable

C. Refuse Collection Areas and Dumpsters

- (1) All structures and facilities for trash, storage, loading and outdoor equipment shall be screened from view from any street or pedestrian circulation area with architectural features and landscaping.



Figure 32 Left – Not permitted

Right –Required Treatment

- (2) All dumpsters shall be placed in the rear yard and may be located five feet from the property line if the adjoining property is zoned non-residential and five feet from all applicable buffers if the adjoining property is zoned residential.
- (3) All dumpsters shall be enclosed with a wall of equal or greater height on three sides, the material of which shall be similar to the material on the outside of the main building. The City Planner may approve alternate materials on request, but in no case shall materials be approved which will quickly degrade such as wood fencing.
- (4) The doors of a dumpster enclosure shall not face a public street when there is no visual buffer between such enclosure and the street.

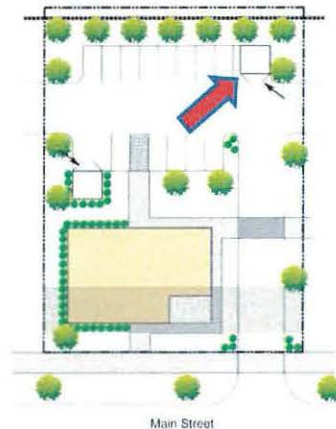

Figure 33 A- Preferred Treatment Example

B – Example Preferred Location

**D. Site Furnishings**

Street furniture serves to unify the downtown. Street furniture compliments downtown sidewalks and creates places of rest and interest along the route. Street furniture should conform to a unified style and character that defines the identity of the street. Furnishings should be placed in areas of pedestrian activity.

**(1) Street Furniture Standards:**

Street furnishings include but are not limited to; trash receptacles, benches, seating, bus shelters, bike racks, newspaper boxes, vending carts, tables, pedestrian way finding signage, kiosks, and public art.

- (a)** Street furnishings may be installed, if desired, along all corridors.
- (b)** Furnishings may not be installed in a sidewalk clear zone.
- (c)** Public furnishings in the right-of-way including benches, waste receptacles, recycle receptacles, signage, and bicycle racks must be secured or anchored to the ground unless otherwise approved by the City Planner.
- (d)** Street furniture shall be installed in the street furnishings zone between the curb and sidewalk.
- (e)** Street benches must be comfortable, structurally sound but simple and pleasant to look at.
- (f)** Benches should be placed in areas of the greatest pedestrian use such as plazas, near intersections, alcoves adjacent to building entries, and along sidewalks downtown under tree canopies.
- (g)** Benches used along downtown sidewalks should be placed parallel to the street facing the buildings nearest them approximately two feet from the back of the curb. One to two benches per block are recommended.
- (h)** Benches shall be secured to the ground with a footing at all four legs. Methods of attachment shall not be welded and shall be capable of being removed for servicing the area beneath the bench as needed.
- (i)** Benches shall be made of all metal, or metal and wood. Benches of recycled plastic and similar plastic materials are not permitted due to their propensity to degrade in quality and appearance very quickly. Other materials such as pre-cast concrete may be approved by the Planning Commission.



**Figure 34** Typical Public Bench

**(2) Trash / Ash Containers**

- (a)** Trash receptacles should be of a consistent design that is attractive but functional. Trash receptacles should be placed in areas of greatest pedestrian movement such as

near the curb at street intersections, in plazas, and around businesses that generate lots of trash such as restaurants and cafés.

- (b) Trash receptacles shall not be placed within 6' of a bench.
- (c) Trash receptacles often leak liquid waste and should therefore be placed over landscape strips with mulch or gravel below them when possible.



Figure 35 Waste Receptacles Typical

(3) Public Art

For art to be considered public it must be placed in the public realm for public use. Art placed in the front entry plaza of a private business property that is readily accessible and visible from an adjacent public street is considered public art. On the other hand, artwork placed in a rear yard and out of plain site of the general public shall not be subject to the provisions of this section. Note: When a business attempts to gain attention by building a large works of public art, such as a 20 foot tall fish sculpture in front of a seafood restaurant, art can become a “sign”. For this reason, some public art is regulated under the signage section of this article.

- (a) All permanent public art weighing more than 20lbs must be anchored or secured to the ground or otherwise made safe from tipping or falling.
- (b) Public art must respect the significant potential for citizens touching, climbing on and or interacting with the art. Therefore the pieces must be sturdy and free of sharp points or projections that could endanger the public or alternatively the art must be placed in such a way that the public’s direct access is limited.
- (c) Public art shall compliment the character of the downtown overlay district and shall appeal to a large percentage of the population. The subject matter shall not be overtly controversial in nature.



Figure 40 Left and Right Show Examples of Desirable Public Artwork

- (d) All artworks greater than 8' in total height or 12' in width shall also be subject to the signage sections of this article (fountains excluded).

EXHIBIT A

Downtown Overlay District  
Design Standards

Version:

- (e) Any painted murals that include words are subject to the provisions of the signage sections of this article.



Figure 41 Typical Mural Example – Requires DDRC Approval

- (f) All art placed in the public right-of-way is subject to the approval of the Public Works Director.
- (g) Private artwork placed on property within the downtown overlay district that is readily visible from a public street is also subject to review by the Planning Commission.

(4) Mail Boxes

Mail boxes shall be selected and located so that they are unobtrusive and visually integrated into the environment or so that they are appropriate in design and location with the architecture of the building. The City finds that the focus of the downtown should be on the landscape and architecture and not utilitarian items such as mailboxes. As such:

- (a) All mail boxes shall comply with USPS minimum standards for placement and construction.
- (b) Mail centers or groups of boxes for commercial building shall be placed so that they are easily accessible and under cover. They shall be designed into building walls or in separate structures which are architecturally integrated with the overall character of the site.
- (d) The location and design of all commercial mailboxes shall be subject to review and approval by the DDRC.



Not Allowed  
Figure 42



Standard – Allowed



Alternate - Allowed



Figure 43 Acceptable Mail Center Styles for Large Developments

(5) Bus Stops/Shelters

Bus stop shelters may be required along some corridors in the downtown overlay district. Developers shall consult with the Public Works Department to determine if development requires coordination for a bus stop location in the public right-of-way. The City may at some time in the future create a custom bus shelter design for use in the Downtown Overlay District and or other areas. Until such time, all bus stops requiring a shelter in the Downtown Overlay District shall require review and approval by the Public Works Director and must meet the following minimum standards:

- (a) The roof shall be curved and constructed of either standing seam metal of a reflective color or a glass like material such as Plexiglas.
- (b) The provision of advertising space at bus shelters is not allowed.
- (c) The shelter shall provide a center or back wall of glass or glass like transparent material and painted metal posts for protection from the wind.



Figure 44 Example Shelter



Advertising is not permitted but local information such as maps, public events, calendars, etc. are allowed.



Figure 45 Example Shelter with information

**4 Landscaping**

Landscaping should provide aesthetic enhancement of a project site, screen objectionable objects from public view, and replace scarred slopes of missing vegetation impacted by grading activity. A successful landscape project will consider the appropriate use of plant materials, proper plant spacing, and long term maintenance needs for each plant type as noted herein.

Trees and shrubbery break up the monotony of concrete and asphalt in a downtown area by providing greenery, flowers, seasonal change, and shade. Trees break up the scale of large buildings. Shrubs not only add color and texture to a streetscape, but shrubs can also provide excellent screening to hide blank walls, unattractive foundations, parking lots, trash bins, loading docks, and outside storage areas.

**A. Professional Design Requirements**

All landscape plans submitted for review to the City Planner shall not be required to be prepared and stamped by an Alaska registered architect with experience in urban design.

**B. Locally Proven, Hardy, Urban Plants**

All proposed plantings shall be climactically appropriate for use in this locale. Plants shall be selected from those known to be hardy and adapted to the prevalent environments of the City of Wasilla. Plants known to have major maintenance, pest or disease problems shall not be used.

**C. Public Safety Regarding Dangerous, Noxious and Invasive Plants**

All plants placed in areas readily accessible by the public shall be appropriate for public use. Additionally some aggressive species of plants can spread rapidly outside their intended planting areas through seed dispersal or other means. These plants can quickly become a serious public nuisance. Planting of significantly poisonous plants and/or plants with large thorns is not permitted in any public area or areas generally accessible to the public.

**D. Sight Distances and Plants**

No section, portion, or requirement in this article is meant to construe that any plant including street trees, shrubs, groundcover, or other plantings shall be placed or planted within a site visibility triangle. All sight visibility triangles for intersections of driveways, service roads, curb cuts, or streets shall be kept clear of shrubbery over 24" in height or any plant or plants that would limit visibility at the standard elevations set out and established in the various AASHTO and AKDOT&PF design manuals and standards. If other sections of this article conflict with this requirement, this section shall prevail above all others.

**E. Entry Landscaping**

Entry way landscaping is encouraged and should include design elements which are common to the proposed development. Design elements may include, but are not limited to, entry wall monuments, perimeter fencing, landscape berms/mounds, water features (such as fountains or reflecting ponds), specimen trees, and upsized shrub plantings.

**F. Frontage Landscape Requirements**

The following street frontage landscape requirements apply to any side of a property that fronts a public street and includes only the land within the public right-of-way:

- (1) Street trees are required and must be placed within the landscape strip/furniture zone between the curb and sidewalk.
- (2) Except for the minimum 32 square feet of pervious space required for each tree the remaining area of the landscape strip may be paved with brick pavers.
- (3) The trunk of the tree may be no closer than 20" to the sidewalk at time of planting.
- (4) Street trees shall be planted at a minimum of one (1) every 40'.
- (5) Except for driveways, walls, sidewalks, and utilities, the remaining undeveloped surface of the frontage shall be paved with decorative pavers or be permanently planted in turf grass, ground cover plantings or shrubbery.

**G. Walls (other than building walls), Columns and Piers**

- (1) The following standards apply to common fences and walls around businesses along public street frontages. (The following standards are in addition to any other standards that may be set forth in the City of Wasilla's Municipal Code.)
- (2) Allowable materials include: natural stone, clay brick, architectural concrete, or wood.
- (3) When the building fronts and sides are visible to a public street, any wall over two feet in height from finished grade shall not be opaque and shall have a minimum opening ratio of 50%.
- (4) When the back of the building is visible to a public street, walls shall be opaque (solid).
- (5) Applications for wall permits shall be reviewed by City Planner.

**H. Fences**

- (1) Fencing made of barbed wire, razor wire, plastic, or cloth is prohibited unless otherwise stated in the City of Wasilla's Municipal Code.
- (2) All fences shall be at least 4 feet in height and not greater than 8 feet.
- (3) Simple plain wood picket fences are not allowed.
- (4) When the building fronts and sides are visible to a public street, any fence shall have a minimum opening ratio of 50%.
- (5) When the back of the building is visible to a public street, fences shall be opaque (solid).
- (6) Chain link fencing is not allowed to front a public right-of-way. Chain link fencing is permissible only for the following uses only:
  - (a) Along a rear or side property line as long as that fence is not readily visible from a public right-of-way or adjacent property owner.
  - (b) As a small enclosure for securing utilities or materials as long as such enclosure is not readily visible from a public right-of-way or adjacent property.
- (7) Applications for fence permits shall be reviewed by the City Planner.

**I. Parking Lot Landscaping**

- (1) Where a parking lot or parking structure fronts directly on a public street, a continuous screen of evergreen planting (to be equally effective all year) shall be provided. Said screen shall be a minimum height of 2' at time of planting and capable of attaining a healthy maintained height of 4 - 5' or greater. The minimum bed width of the screen shall be 4'.

EXHIBIT A

Downtown Overlay District  
Design Standards

Version:

- (2) Parking lots shall be planted for the harsh environment they create. Trees, shrubs, and ground cover must be heat tolerant and well suited for the confined spaces they are planted in.
- (3) All trees in parking lots shall be medium to large canopy trees from the approved planting list. Other species of a similar type, height, canopy, etc. may be approved by the City Planner on request.
- (4) All trees shall be a minimum of 2.5" caliper and 8 feet tall at time of substantial completion.
- (5) All parking lot islands shall have construction debris including slag concrete, gravel, and asphalt removed completely. Fill soil and subgrade materials that have migrated into the islands during construction must be removed completely to a depth of 36" from the top of the curb or top of paving if no curb exists.
- (6) Islands and peninsulas shall be filled with a planting mix and or top soil or both to achieve the desired finished grade. Do not crown beds more than 3-6" as this will cause most of the water to run-off before it can percolate into the soil.
- (7) Evergreen ground covers or shrubs with mulch shall be utilized in parking lot landscape islands beneath the required trees. Turf grass is not permitted.

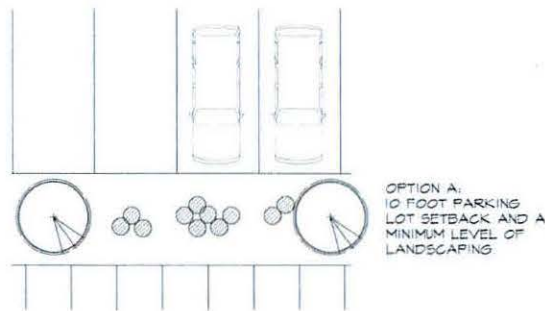

Figure 46 Typical 10' Landscape Strip – Mixture of Plant Sizes

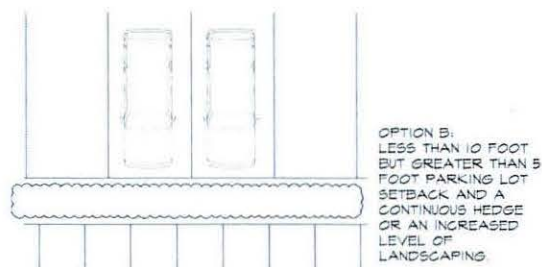

Figure 47 Typical Reduced Landscape Strip – Requires Hedge

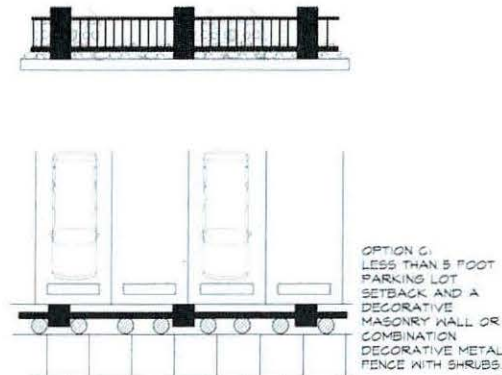

Figure 48 Typical Reduced Landscape Strip – Requiring Fence

**J. Plazas, terraces, patios and other paved areas**

- (1) Public hardscapes shall be detailed with decorative pavers, low walls, seating, etc. to create inviting open spaces.
- (2) Designs shall compliment the surrounding facilities and buildings and are subject to review and approval by the City Planner.
- (3) Anti-vandal devices that discourage skate boards and other similar uses should be integrated into designs of steps, cheek walls, and railings.

**K. Fountains**

All publicly accessible outdoor fountains are subject to these requirements as well as all applicable local and state codes and standards:

- (1) All fountains must be designed by qualified designers possessing experience with fountain mechanics.
- (2) All fountains shall be designed to account for “shut-down gain” and have overflows routed to sanitary sewers if they are using treated water.
- (3) Fountains should be designed to look attractive even when not operating so they are still attractive in periods of drought, winter, or repair.
- (4) Fountains with reservoirs large enough that they might attract bathers are required to provide visible but discreet regulatory warning signs forbidding bathing or related activities.
- (5) All fountains are required to be kept in working order and in operable condition at all times except when weather conditions make it impossible to operate or when required to be shut off for repair.

**L. Parking Deck Landscaping/Screening**

- (1) When an owner/developer decides to screen a parking deck wall or side they must provide a landscape area or bed with a minimum depth of 8 feet containing at least one understory or over story tree, as appropriate, and 8 shrubs per 40 linear feet, and a minimum of 90 percent living shrubs, groundcover, sod, and/or annual or perennial color in the landscape strip surface area.
- (2) The areas between the trees must be landscaped or grassed.
- (3) The trees shall be evergreen and columnar or pyramidal in shape and be at least 10 feet tall at the time of planting.
- (4) Trees employed to meet the screening requirement may be counted toward the street tree and overall density planting requirements.

**M. Buffers**

- (1) Buffers shall comply with buffer standards in Title 16 of the City of Wasilla Municipal Code except that the following provisions shall be in addition:
  - (a) A buffer shall consist of at least 50% evergreen species. In situations where existing buffers are mostly deciduous or mature trees with no understory, evergreen shrubs and trees shall be added.
  - (b) Any undisturbed buffer that is not 100% effective at screening at time of planting must be improved with additional plantings or fencing so that the view is fully obscured at 5 feet height.
  - (c) When gaps or large areas of the buffer contain no shrubs or trees or when the buffer has to be disturbed for a perpendicular utility crossing, the buffer must be replanted with shrubs and trees in sufficient quantity to screen the site completely at 5' height.
  - (d) A fence may be used in addition to plants to increase the buffering capabilities as desired.

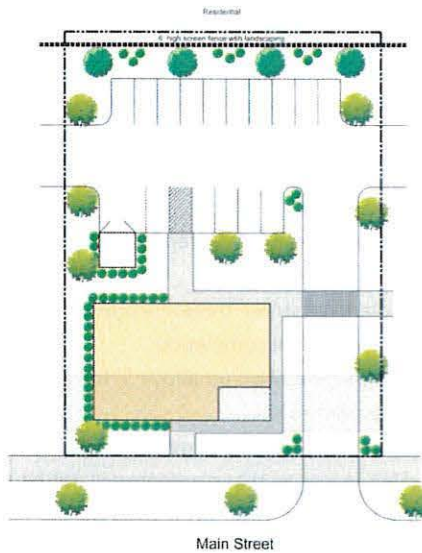

Figure 49 Landscape Buffers and Fences

**N. Street Trees**

Street trees are required along the streets in the Downtown Overlay District. Due to the difficult growing conditions for urban trees, it is important to use species which are well adapted for these conditions. Street trees for purposes of downtown Wasilla will be divided into two types. The first type is called the “canopy tree” which is the larger of the two types and will be used along sidewalks. These trees provide sufficient space for pedestrian movement under them and vehicular visibility.

- (1) Acceptable street trees and shrubs shall be approved by the City Planner and Public Works Director.
- (2) A row of street trees along one road must be of a single species on any single property or block. (Note: other required trees on property need not be of a single species.) If previous developments have occurred on the same road, the species of trees approved and planted previously should be continued unless a different species is approved by City Planner.
- (3) All matching street trees on one road frontage or in a continuous block shall be well matched in form and character.

- (4) Street trees (overhead canopy trees) are required at a minimum of 50' intervals or portion thereof, and spaced roughly equal distance between each tree. Spacing shall not be less than 35' on center except in situations where specific screening of a building, utility, or equipment is required. Spacing of street trees placed along the same road shall be as close to equal as possible.
- (5) Street tree placement shall accommodate the clear zones required by site triangles.
- (6) No tree trunk shall be placed closer than 5' from the back of curb.
- (7) No tree trunk shall be planted closer than 10' from a building wall.
- (8) When street lights are present trees shall not be closer than 15' from a street light and spacing of trees should correlate with lighting to create roughly equal spacing and regular patterns of lights to trees. Spacing shall be subject to the approval of the City Planner.
- (9) All street trees to be installed shall be a minimum of three caliper inches. Replacement trees for trees damaged by vandals, storms, pests, disease or vehicles shall be installed to match the existing trees when possible; or the largest size possible from locally available commercially grown sources.
- (10) Street trees planted in a sidewalk cut must be provided a minimum pervious area of 32 square feet measuring 4' by 8' with the longer side running parallel with the street. This area may be covered by gravel, mulch, or ground cover but grates are not permitted. Other coverings such as flexible pervious pavements may be approved by the City Planner by special request.
- (11) Root barrier systems are required at the tree base when planted in sidewalk cuts (tree planters).
- (12) Developers planting street trees on public property shall guarantee them for a full year from time of substantial completion.
- (13) Street trees shall be limbed up above 5' for visibility and at least 7' in situations where they are over pedestrian zones.
- (14) In locations where street-side parallel parking occurs directly adjacent to a street tree, locate parking spaces so that car doors will not hit tree trunks.
- (15) Trees that are known to produce heavy crops of nuts, seeds, fruits or other significant organic debris shall not be acceptable for street trees.
- (16) All street tree planters shall be planted with a permanent evergreen ground cover and or annual flowers.

**O. Approved Plant Lists**

All plant and tree types must be approved by the City Planner and the city Public Works Director.

**5 Lighting**

A well-lit downtown promotes and enhances safety. Aesthetically pleasing light which does not create a glare or light pollution can create an ambiance that is inviting and even contribute to creating a sense of place. Selecting low wattage long life fixtures can save energy and promote sustainability in all development. Lighting should serve both the vehicular and pedestrian circulation. The consistent use of a coordinated family of lighting fixtures throughout downtown helps to further unify the area.

**A. Lighting Standard Requirements**

- (1) It is the policy of the City that all street and sidewalk lighting design shall be based on ANSI/IESNA RP-8-00.
- (2) All lighting designs for the downtown area must be submitted to the City for review with the necessary back-up material. Shop drawings, lighting design data, cut-sheets, etc. must

be provided. Where the City's standard details are not applicable, the designer shall submit the appropriate cut-sheets(s) and the proposed lighting plans to the City for review. No design shall proceed without the City's approval of the lighting plan and photometric layouts.

- (3) All lighting fixtures used shall be as specified in this section or an approved equivalent. Substitutions must be approved by the DDRC and have equivalent maintenance requirements, luminaires, power consumption, and lamping requirements in order to avoid unnecessary long term maintenance complications.
- (4) Specific lighting fixture placement and fixtures cut sheets must be shown on the plans submitted for review.
- (5) All lighting fixtures must come with a manufacturer's warranty of at least 5 years on components, workmanship and finish.
- (6) All light level requirements are to be tested at ground level or pavement surface.

#### B. Streetlight Requirements

- (1) Street Lights shall be used along all roads.
- (2) The light levels to be provided are to follow IES recommended guidelines.
- (3) Streetlights shall be spaced roughly equidistant between all required street trees. Small deviations in regular spacing shall be permitted for previously installed utilities, streets, curb cuts, etc.
- (4) Street lighting may be provided through both public and private lighting providers.
- (5) Street lighting shall be sufficient to provide for safety at intersections and heavily trafficked areas for both vehicles and pedestrians.

#### C. Store front Lighting

- (1) Window display lighting should be the dominant light. Other elements of the building should have more subdued lighting.
- (2) Lighting shall be used in the storefront display window, around signage, entrance, and as an accent for building details.
- (3) The lighting shall be indirect from either concealed fixtures or from decorative light fixtures in keeping with the style of the building.
- (4) Storefronts shall utilize building mounted lighting to uplight any building mounted signage including addresses and businesses name.
- (5) Protruding fixtures should complement the architecture and if necessary be painted in a weather resistant finish. All mounting hardware should also be appropriately weather resistant.

#### D. Parking lot lighting

- (1) Lighting in the parking lots and areas of pedestrian circulation shall be sufficient to avoid areas less than 0.2 Foot Candles and provide light levels adequate for safety.
- (2) Shall not allow the use of incandescent or high pressure sodium (HPS) fixtures.
- (3) All parking lot lighting in the parking lot or lots of one development shall be accomplished with the same fixture or family of fixtures when more than one type is used.
- (4) All parking lot lighting shall be accomplished using cut-off style fixtures and anti-glare shields as needed to reduce light spill onto adjacent properties.

#### E. Pedestrian/Sidewalk Lighting

- (1) Pedestrian lights shall be used primarily for lighting sidewalks and public plazas near the street and shall maintain a minimum 0.2 foot candles on all areas of the sidewalk.
- (2) Pedestrian lighting shall be installed when new or upgraded sidewalks are constructed.

- (3) Pedestrian lighting shall be spaced to provide adequate light levels for sidewalks based on providing not less than 0.2 foot candles on any part of the sidewalk (exclusive of areas shaded by trees). Spacing shall be roughly equal and provide safe distance from required street trees.
- (4) If designed with the fixture extending at an angle from the pole, the light fixture shall overhang the sidewalk.
- (5) Fixtures in the public right of way shall be a maximum height of 16 feet and shall match or otherwise compliment the approved street light standards.
- (6) Fixtures on private property shall also match or compliment the approved lighting standards however they may at times deviate to match or compliment the architecture of the building subject to the approval of the City Planner.
- (7) On intra-parcel sidewalks, fixtures shall be installed to maintain a minimum lighting level on the pathway of 0.2 foot-candles and may be of any style appropriate to the architecture of the project.
- (8) Pedestrian lighting shall be located outside the required clear zone of sidewalk. The street furnishings zone is the preferred location.

**F. Cut-Off Style Lighting Requirements**

Light pollution is an unwanted consequence of outdoor lighting and includes such effects as sky glow, light trespass, and glare, which are defined below:

- Sky glow: Brightening of the night sky caused by natural and human-made factors.
- Light Trespass: Light being cast where it is not wanted or needed.
- Glare: Objectionable brightness.
- Disability glare: Loss of visibility from stray light scattered within the eye.
- Discomfort glare: Sensation of annoyance or pain induced by overly bright sources.

- (1) In an effort to lead by example, the City has elected to adopt lighting standards similar to those developed around the country to help limit light pollution, glare and energy waste.
- (2) Therefore all public street and pedestrian lighting shall be of the cut-off style and shall not create light pollution or glare per IES Guidelines.
- (3) Any light fixtures submitted for approval by the Public Works Director shall meet the IES Cut-Off Style Guidelines and requirements.

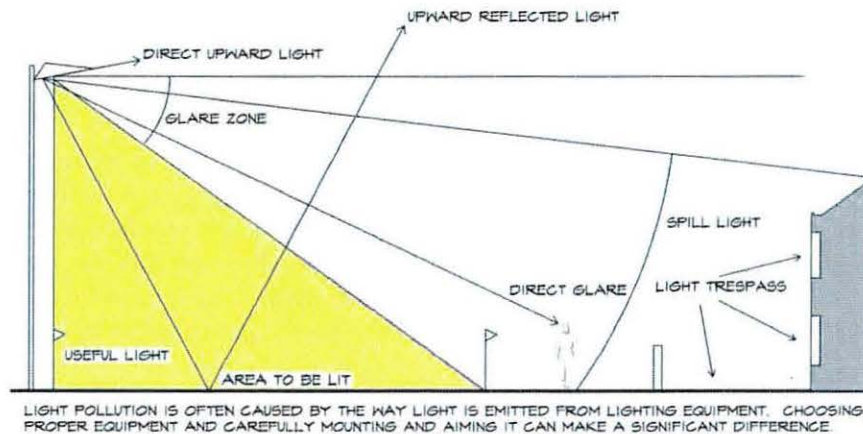

Figure 55 Light pollution can be eliminated or reduced by choosing the right fixtures



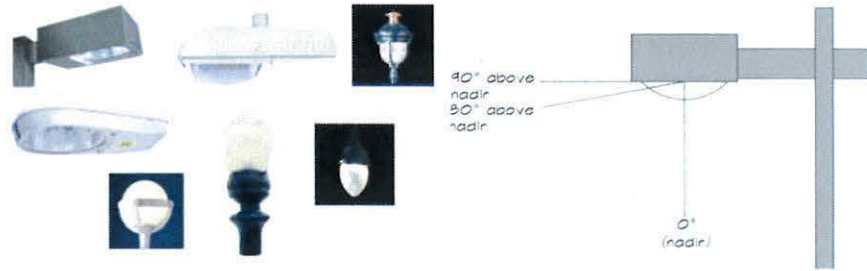

Figure 56 Sample of Cut-Off Style Light Fixtures and Diagram

6 Signage

Signs are an integral part of any downtown business area. A business sign can call attention to a store and help establish a business brand or image. Merchants often try to “out do” each other with large flashy signs. However, bigger, brighter, and attention grabbing signs are not better and often harmful and detract from the quality of life in the area. In the Downtown Overlay District, smaller, high quality, pedestrian-oriented signs that are often integrated with the building or high quality well detailed monument signs are required.

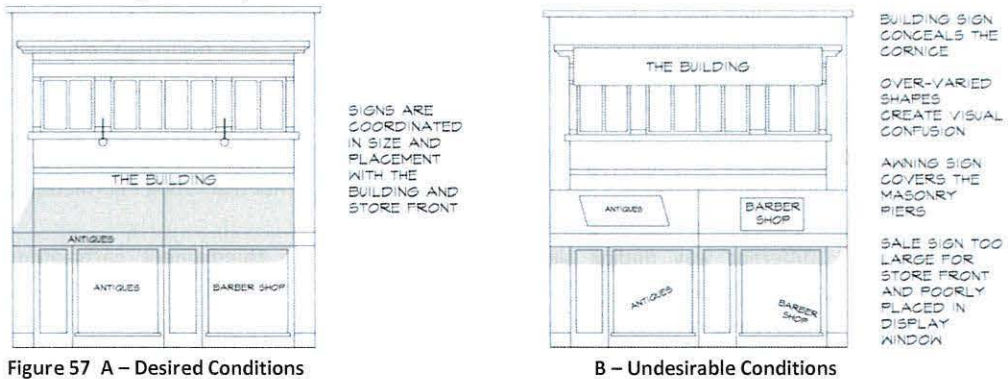

Figure 57 A – Desired Conditions

B – Undesirable Conditions

A. General requirements for all Signage

- (1) Requirements of the current sign regulations in WMC 16.32 apply to the Downtown Overlay District except as follows:
  - (a) Stanchion signs are not permitted in any part of the Downtown Overlay District except those that are grandfathered.
  - (c) Wall signs may project beyond the building face up to six (6) inches. Awning signs may be placed on any surface of the awning as long as that awning does not project over the public right-of-way or building set back line.
  - (d) The maximum height of a wall or awning sign shall be twenty four feet (24’). The minimum height to the bottom of a wall sign shall be eight feet (8’).
- (2) If a rear customer entrance is provided, a small version of the main entrance sign may be used to denote the store’s rear entrance.

B. Sign Colors

- (1) Colors shall be consistent with the architecture and theme of the building.
- (2) Day glow and fluorescent colors are not permitted.
- (3) Spots, stripes, lines, and similar patterns of paint shall not be permitted on signs unless part of corporate logo.

Downtown Overlay District  
Design Standards

Version:

**C. Sign Materials**

Materials shall not be limited except that all materials shall be appropriate for use in wet conditions if they are to be exposed to the elements. Signs may be made of wood, plastic, metal, or stone or any combination thereof.

**D. Lighting of Signs**

- (1) Signs shall be indirectly lighted.
- (2) Back lighting or internally lighting signs is not permitted except when signs are incorporated into awnings or on buildings and indirect lighting is not possible.
- (3) Free standing signs shall be lit indirectly and not backlit.
- (4) Neon Signs
  - (a) Neon signs are not permitted outside of any buildings.
  - (b) Neon signs may be used inside of businesses as long as they are not larger than 48" in either direction and no more than one per 10 percent of the window space is used.

**E. Digital Signs**

- (1) Digital or electronic signs on which the display changes intermittently are not permitted except by special approval by the Planning Commission.
- (2) Large TV's or similar projection devices with screens over 32" in any dimension including digital signs placed inside of buildings that have windows or openings shall be placed and angled so the screen is not readily visible from the street. Any such device of any size, used as a sign with messaging is not permitted.

**F. Directional Signage**

Directional or way finding signage shall be provided as needed for a site requiring such signage.

- (1) This signage shall not include any logo, emblem or other marketing information and is only to be used for directing traffic.
- (2) Different way finding signs shall be designed to complement each other and the architecture.
- (3) Colors and materials shall match or compliment other site furnishings.
- (4) Way finding signs shall not exceed 6' in height nor exceed 4 square feet each.

**G. Prohibited Sign Types**

- (1) Signs with supporting members less than one-third of the width of the sign face (known as "pylon, pole, or lollipop" signs) are prohibited.
- (2) Freestanding and monument signs

**H. Wall Mounted Signs**

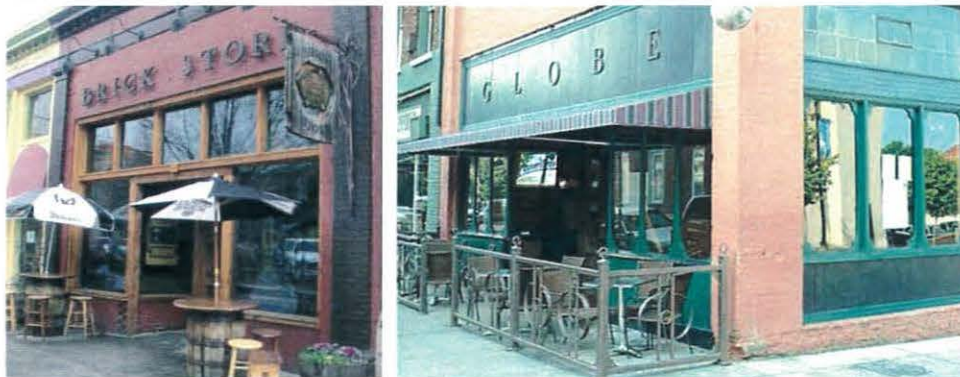

Figure 59 A – Acceptable Examples

B – Typical Acceptable Wall Sign

## EXHIBIT A

### Downtown Overlay District Design Standards

Version:

- (1) Every business is entitled to have one street-facing wall sign per street frontage.
- (2) Any business without a free-standing sign or a protruding sign and has more than one exposed side may have two wall signs which shall meet the following standards:
  - (a) Both wall signs may not be on the same wall.
  - (b) The street facing wall sign shall not exceed 5 percent of the applicable wall area.
  - (c) The non-street facing wall sign shall not exceed 5 percent of the applicable wall area.
  - (d) The total of both signs shall not exceed 225 square feet.
- (3) Wall signs may be incorporated into a retaining wall or other site hardscape feature, as recommended by the City Planner.
- (4) In lieu of any free-standing signs, a building containing four or more tenants shall be allowed additional wall sign area to place the name of their center on the building. The allowable sign area shall be 5 percent of the applicable wall area, not to exceed 180 square feet, whichever is less.

#### I. Awnings and Canopies

All graphics within the entire illuminated area of the awning or canopy shall be calculated toward the allowable wall sign area.

#### J. Protruding Signs

- (1) Protruding signs are permitted and encouraged in the Downtown Overlay District.
- (2) Protruding signs may not protrude more than 6' from a building face; the lowest portion of any such sign shall be a minimum of 8' above the sidewalk or pedestrian zone.
- (3) Protruding signs must be securely fastened to a structure capable of supporting the weight and tension created by the sign.
- (4) Protruding signs shall be free to artistically highlight the businesses brand and style. The use of intricate metal work, carved wood, wrought iron and similar designs is encouraged. The following examples illustrate the type of sign desired in the Downtown Overlay District.



Figure 60 A thru E – Typical Examples of Acceptable Signage

**K. Window Signage**

- (1) Window signs are any signs placed on the glass both inside and out.
- (2) No signs are allowed on the outside of windows at any time.
- (3) Seasonal signs and messages related to holidays or special events may be painted on windows as long as the message area does not exceed 30% of the window.

**L. Address and Unit Numbering**

Every commercial or retail building shall have the street address or building number clearly visible to the street for which the address applies.

- (1) The street address numbers shall be mounted or painted on either the free standing sign facing that street or placed above or adjacent to the main entrance door on the corresponding street.
- (2) The address shall not be displayed on signs that abut or face the right-of-way of other streets to which the address does not apply.
- (3) The size of the letters shall be suitable for viewing from the street and be a minimum of six (6) inches but not more than twelve (12) inches.
- (4) The color and material must make the numbers clearly stand out from the wall or sign in the background but should not be obtrusive in color. Black or white or simple solid colors are preferred. Pin mounted metal numbers are the most desirable. Tiles with painted numbers are also acceptable.

**M. Artwork Perceived as Signs**

Sometimes artwork is constructed in order to attract business and not simply to beautify the open space. When an artwork such as a sculpture is greater than one story or approximately 8' in height or 12' in width, it tends to become an icon and therefore more of a sign than a piece of art. It is the intent of the City of Wasilla to control these types of elements. Therefore:

- (1) Any sculptural or painted artwork exceeding 8' in height or 12' in width must be qualified as public art before it can be permitted.
  - (a) To be qualified as public art, a scaled design concept or mock-up must be presented to the Planning Commission for review.
  - (b) The Planning Commission will meet to make the determination.
- (2) Any works perceived by the Planning Commission to be a sign shall not be permitted to be constructed. A typical example of artwork subject to this provision would be a large fish sculpture in front of a seafood restaurant.



Figure 61 Example of Questionable Public Art

**7 Building Construction Standards**

Downtown structures are traditionally located adjacent to sidewalks and neighboring buildings. Buildings located along sidewalks clearly define the street edge. This building placement also creates a pedestrian-friendly atmosphere that entices people to explore and invites them into the buildings.

Throughout the United States these type of design symbolizes “downtown” in the minds of most citizens and Wasilla requires these design elements to be incorporated into new construction in the Downtown Overlay District. The goal of the Downtown Overlay District Design Standards is to create unique, well-designed building facades that will remain viable in the future and ensure the economic stability of the downtown area for future generations.

**A. New Construction Standards for Buildings and Structures**

**(1) Building Height**

The appearances of individual buildings collectively create the visual image of an entire downtown. Varying building heights in the Downtown Overlay District will help create a pedestrian scale with architectural interest.

- (a)** Maximum building height is three stories or 50 feet, whichever is less.
- (b)** Buildings are encouraged to be two or more stories.



Figure 62 A – Examples of building variation



B- Example 2 story with prominent features

**(2) Architectural Styles**

The Downtown Overlay District does not require buildings to be designed to a particular style and instead requires buildings to be built to provide a diversity of styles with the particular dominating theme of timelessness. The intent is that there is enough diversity of both traditional and modern styles so that a change in any one building will not negatively impact the style and overall character of the downtown area. Therefore:

- (a)** No building may match the exact style and treatments of its neighbor.
- (b)** Owners are encouraged to create diversity of styles between buildings but also to include a small amount of similar details or materials that compliment or match neighboring buildings in order to promote a sense of continuity.
- (c)** When a particular style is selected by an owner it should be true and architecturally correct to the period.
- (d)** Occasionally it is appropriate to interject a building that radically departs in style and or materials from the adjacent neighbors. These buildings help develop the sense of character and create the talking pieces and interest of the downtown overlay district. They also help to break up the strip center feel that a block of similar buildings can create.

## EXHIBIT A

### Downtown Overlay District Design Standards

Version:



Figure 63 A – Proper Treatment

B – Improper Treatments

- (3) Building Harmony
- (a) Out-parcel buildings, which are identified on a site plan approved pursuant to a single zoning case, shall have architectural features consistent with the principal buildings.
- (4) Building Scale and Massing
- The use of smaller scale building components reduces the perceived scale of large buildings, and maintains the sense of pedestrian scale in a downtown. Variations in building mass enhance the visual image of the downtown by creating architectural interest and vitality. A simple long wall is not permitted in the Downtown Overlay District.



Figure 64 A – Not permissible



B – Desired example with variation

- (a) Discontinuous building massing for large buildings: Buildings shall reduce their perceived height and bulk by dividing the building mass into smaller scale components.
- (b) Building walls exceeding 75 continuous horizontal linear feet shall utilize offsets, such as projections, recesses, and changes in floor level.
- (c) In addition, any commercial building with primary tenant spaces greater than 50,000 square feet shall be structurally designed to be easily divided into smaller tenant spaces.
- (d) Discontinuous building massing for small buildings: Individual buildings may share the same setback for any 75-foot linear span as measured along the curb line. Beyond seventy five 75 linear feet, individual buildings shall setback a minimum of two feet greater or lesser than the adjacent building's setback.



Figure 65 Example showing minimal changes in building faces and awning to create character.

(5) Building Materials

The use of quality building materials relating to trends in established historical materials found on existing downtown buildings is essential to maintaining a consistent relationship among the downtown structures. Each building should use materials and design that compliment that of its neighbor with few exceptions.

(a) Prohibited Materials:

- (i) Prohibited exterior building materials include materials which are not textured; non-architectural metal panel systems, as-cast smooth concrete masonry or plain reinforced concrete slabs, aluminum, plywood, press-wood or corrugated steel (exceptions: mechanical penthouses & roof screens).
- (ii) Prohibited exterior building components, if visible from any public street, include: steel gates, burglar bars, chain link fence, and steel roll down curtains. If not visible from any public street, such treatments are allowed.
- (iii) Imitation brick panels, rough textured wood siding, concrete pavers (used vertically) and traditional metal and plastic siding are prohibited

(b) Traditional materials such as glass, clay brick, terra cotta, stucco, and natural stone shall be used.



Figure 66 A – Example with materials variations



B – Example showing brick and precast

## EXHIBIT A

### Downtown Overlay District Design Standards

Version:

- (c) Four-sided design is required and discontinuity of building materials is prohibited. For example, if brick is placed as the major element on the primary front wall of a building it must continue on all four sides in similar fashion. However, if a material is only used as an accent and is not the dominant material it does not have to be re-used on other walls.
  - (d) All exterior walls and facades shall be required to use a minimum of two of the following elements: brick, glass, wood, real stucco, or stone. No single element shall constitute greater than 80 percent of the total of the elements used.
  - (e) Exterior walls for all new buildings shall consist of a minimum of seventy percent (70%) of one or a combination of the following durable materials: brick; tile; stone; textured traditional cement stucco (real stucco); architectural concrete masonry with fluted, split-face, or broken face finish; portland cement plaster and lath systems; architectural (either pre-cast or tilt-up) concrete either fluted or with exposed aggregate finish; or fiber cement-board.
  - (f) Sloped roofs shall be standing seam metal, slate, concrete roof tiles, or composition shingles.
  - (g) Exterior building walls, decorative elements, and parapet or cornices are exempt from the building material requirements if they meet the following conditions:
    - (i) If the exterior wall is not visible from any public right-of-way; and
    - (ii) If the exterior wall does not include a public entrance.
- (6) Roofs and parapets
- (a) Commercial buildings shall comply with the following standards:
    - (i) Variation in building rooflines for small buildings: Individual buildings may share the same roofline and roof pitch for any 100-foot linear span as measured along the curb line. Beyond 100 linear feet, individual buildings shall vary the roofline and roof pitch from that of the adjacent building's roofline and roof pitch.
    - (ii) Variation in building rooflines for large buildings: Variation in the roofline of buildings and offsets in pitched roofs and gables shall be required. Parapets in building masses exceeding 100 continuous linear feet shall be varied in height and projection and shall use decorative elements such as crown moldings, dental, brick soldier courses, or similar detail.
    - (iii) A decorative parapet or cornice shall be constructed along all flat roof lines.
    - (iv) Roof-mounted equipment shall be screened from view by a decorative parapet or cornice (point of view shall be across any public street, from the edge of right-of-way furthest from the building).
    - (v) Roof line and building offsets shall be varied by a minimum of two feet for every three tenant spaces or 75 feet of building face, whichever is greater.
- (7) Storefronts
- Variations in individual storefront designs create architectural interest and will help draw businesses and visitors to the unique downtown area. Storefronts should appear as if they were constructed over a period of time. Storefront differentiation may be accomplished by utilizing a variety of different building materials, paint colors, parapet heights, setbacks, awning types, and window sizes and spacing.



## EXHIBIT A

### Downtown Overlay District Design Standards

Version:



Figure 67 Example showing typical desired storefront and awnings

- (a) Repetitive, uniformly designed storefronts are not permitted in the Downtown Overlay District.
  - (b) Buildings constructed to accommodate more than one tenant shall be designed with substantial architectural differentiation to clearly delineate each individual storefront.
  - (c) Delineation of building floors at the third story above sidewalk level and lower shall be executed through windows, belt courses, cornice lines or similar architectural detailing.
- (8) Street-side Facades of Commercial Buildings
- Most building elevations will be visible from public and private streets, sidewalks, parking areas and/or adjacent buildings. Therefore, all sides of a building are important to the downtown's overall appearance. Building elevations seen by the public are to be made interesting and attractive through the use of windows and architectural features.



Figure 68 Example of acceptable architectural treatments

- (a) Each building elevation shall be fully designed and consistent with the building's primary façade. Discontinuity of building materials or architectural design elements is prohibited.
- (b) First floors and street level floors fronting a street or sidewalk shall not have blank walls.

- (c) Building materials, architectural details and patterns shall be varied per tenant or every 75 feet, whichever is greater.
- (d) New, remodeled and rehabilitated buildings, parking decks, and other structures shall employ street level design elements that relate to a pedestrian scale through the following means:
  - (i) First floor building walls shall have window and door openings of at least 50 percent of its length or one of the other options described below.
  - (ii) Works of art, fountains and pools, street furniture, landscaping and garden areas, architecturally articulated facades, and display areas may also be considered in meeting this requirement.
  - (iii) The length of façade without intervening fenestration or entryway shall not exceed 20 feet.
  - (iv) Fenestration shall be provided for a minimum of 75 percent of the length of all street frontages. Fenestration shall not utilize painted glass, reflective glass or other similarly treated or opaque windows. Entrances may be counted towards fenestration requirements.
- (9) Encouraged Architectural elements  
Encouraged architectural elements include: columns, arcades and covered entry-walkway, arches, facade offsets, windows, balconies, undulating walls, clock towers, cupolas, and courtyards.
- (10) Entrances  
Entrance doors and architraves (architectural door surrounds and moldings) are critical design elements for a building's facade. Entrance doors provide a sense of entry both visually and physically. Doors should be pronounced and welcoming. They should also be recessed to allow space for opening the door, to provide pedestrians cover and shelter, and to create visual interest.
  - (a) Architraves consist of the door casing or brick molding and the surrounding trim. Architraves may be recessed into the wall plane or applied on top of masonry cladding. Small stock trims and standard metal casings should be avoided. Varying door types and architraves from storefront to storefront will differentiate each facade, giving each shop its own unique character.
  - (b) Primary Entrance Orientation: The principal entry area of a building shall be articulated and express greater architectural detail than other portions of the building. Individual tenant space entries shall also be articulated and express greater architectural detail than the building wall.
  - (c) Entrances shall be emphasized with architectural details and oriented toward sidewalks and public rights-of-way.
  - (d) The primary pedestrian access to all sidewalk level uses and business establishments with public or private street frontage shall be directly accessible and visible from the sidewalk adjacent to such street.
  - (e) On corner buildings where both streets are prominent, owners are encouraged to locate the main entrance doors at the intersection as illustrated below. In locations where corner buildings are located on two streets where one is significantly dominant to the other the entry should face the dominant street. In both circumstances a rear entry may also be provided for circumstances having significant parking to the rear.



**Figure 69** Example of appropriate treatment of a corner building

- (f) When parking is situated behind a building, a secondary entrance convenient to the parking lot may be provided; however, the main storefront facade shall be oriented toward the street of which the building is addressed in order to enhance pedestrian activity in the downtown.
  - (g) At least one public (e.g. open to the public during normal business hours) pedestrian oriented entrance shall be located on the street side of the building. There shall be pedestrian access directly from the sidewalk to the principal building entrance.
  - (h) Entrances shall have; awnings, canopies, or other types of covered-projected entry.
- (11) Doors and Windows**
- The traditional downtown storefront is comprised primarily of glass. Doorways and display windows create a visually interesting atmosphere for pedestrian shoppers and may showcase retail products and services. Fenestration (the arrangement, proportioning, and design of windows and doors) is important to creating an atmosphere that promotes the economic success of a downtown business district.
- (a) The use of mostly glass on the first-floor facade is encouraged. Transom windows placed above display windows and raised panels below create accurate architectural details and interest. Storefront glass display windows should be framed by molding painted in accent colors.
  - (b) Transom windows, transom panels and sidelights are traditional design elements that add accurate detail to entrances and display windows. Transom windows may be decorative in nature and do not need to function. When used, transom lights should be placed above the entrance door or display windows. They may also be placed above an awning so that the transom remains visible. Sidelights may be all glass or a combination of glass lights and raised panels.
  - (c) Upper-story windows of downtown buildings can create repeated patterns that tie together downtown facades. With the exception of multiple-story foyers, fixed pane sashes are prohibited; instead the use of decorative lunette windows, transom windows and Palladian windows are encouraged.



**Figure 70** Example showing prominent 2<sup>nd</sup> story windows and focal points.

**(d) Doors:**

- (i)** Entry doors shall be recessed or the building face set back from the sidewalk clear zone to allow space for opening the door and to provide pedestrians cover and shelter.
- (ii)** Primary entry doors for commercial uses shall be composed of more than 50 percent glass.
- (iii)** Door surrounds shall include a combination of sidelights, transoms, paneling, pediments or other decorative features.

**(e) Windows:**

- (i)** Commercial storefronts shall be composed mostly of glass with wood or metal glazing systems.
- (ii)** Large display windows shall be incorporated on the ground floor of all commercial buildings.
- (iii)** Display windows shall be framed with molding or architectural details to visually separate the ground floor from upper stories.
- (iv)** The bulkhead above and below the display windows should consist of brick, stone, raised paneling or trim details.
- (v)** Prominent display windows, bay windows, transom windows and sidelights are required.
- (vi)** Wood or metal muntins and mullions shall be used; vinyl is not permitted.
- (vii)** A combination of transom windows and panels shall be used to compliment storefront windows.
- (viii)** Building facades shall be designed with consistent spacing of similar shaped windows with trim or other decorative molding on all building stories.
- (ix)** Upper-story windows shall have a uniform appearance with the same number of panes, similar trim style and complimentary decorative colors.
- (x)** Movable window sashes are required on upper-story windows; vinyl-clad or fixed panes are not permitted.
- (xi)** Reflective glass is prohibited on ground floors of all buildings. A minimum of 60% of ground level facades shall be transparent glazing.
- (xii)** For building faces oriented toward a street, windows shall be placed at distances no greater than ten (10) feet apart.

## EXHIBIT A

### Downtown Overlay District Design Standards

Version:

- (f) Doors and windows shall be prohibited from being flush with the exterior walls and facades. All doors and windows shall utilize design trim treatments or offsets to accentuate said doors and windows.
  - (g) The Planning Commission may grant design exceptions to the door and window design criteria if a proposed project is a unique and exceptional design concept that architecturally enhances the downtown area.
- (12) Projections
- The use of awnings, decks, porches, and balconies on downtown buildings may provide protection from rain and sun, making the downtown shopping experience more enjoyable. An awning also helps to reduce the scale of the building. Balconies can serve the same purposes as an awning and function to serve the second floor.
- (a) Canvas, vinyl, and decorative metal awnings are permitted.
  - (b) Translucent, plastic, and wood awnings are prohibited.
  - (c) Support poles are prohibited.
  - (d) Dining canopies are awnings that extended over dining areas that can be permanent or moveable so that they may be retracted in good weather or added during inclement weather to protect diners from the elements.
    - (i) Permanent awnings unique to each storefront shall be used; temporary awnings, tarps, or tents are not permitted.
    - (ii) Dining canopies are exempt from size requirements, but all dining canopies must be approved by the City Planner.
  - (e) Upper story balconies hung from exterior walls shall extend no greater than six feet from the building façade.
  - (f) Balcony railings should be constructed of decorative wood, cast concrete, cut stone, or metal materials. Plastic is not permitted.
- (13) Porches and Decks
- (a) All porches and decks must be maintained.
  - (b) The top hand rails of railings for porches and decks of dining areas for restaurants shall not be constructed of wood.
  - (c) Decks and elevated porches are included as building architecture and subject to all building set back and "build-to" lines.
- (14) Architectural Accents
- (a) The trim and sculpted or ornamental elements added to any building shall be appropriate in scale, detailing, and color and shall be accurate elements for the style selected by the architect or owner.
  - (b) The application of elements of art to the face of a building that would not normally be architecturally appropriate may be acceptable only if approved by the Planning Commission.
- (15) Colors
- (a) Building color should be carefully chosen so that each building complements that of its neighbor. An entire block of buildings should blend together even though each building will possess its own identity. The main building is usually painted in more subdued earth tones or brick shades and building trim is painted in a decorative manner in a contrasting shade lighter or darker than the main building.
    - (i) Bright garish colors are generally not permitted.

EXHIBIT A

Downtown Overlay District  
Design Standards

Version:

- (ii) For purposes of the design review the colors are classified by the following categories:  
Base Color – Predominant wall color used on the majority of building surface.  
Trim Color - Used on window trim, fascia, balustrades and posts.  
Accent Color - Used on signs, awnings and door only.
- (iii) A building’s colors shall complement its neighbors, but shall not duplicate the same color scheme of an adjacent building.
- (iv) The Planning Commission may grant exceptions to the approved color palate if desired colors meet the intent and goals of the Wasilla Downtown Area Plan.
- (v) Primary or fluorescent colors shall not be employed except on sign faces, awnings, canopies or as accent colors (not to exceed 10% of building faces exclusive of window areas).
- (vi) Patterns such as polka dots, striping or similar are generally not permitted.
- (vii) Murals – Murals may be acceptable if the concept is approved by Planning Commission. Murals over 8’ in height or 12’ in width are subject to the sign standards and require additional approvals.



Figure 71 Left – Generally Acceptable



Right Generally Not Acceptable

- (16) Accessory Buildings and Structures
  - (a) Accessory buildings and structures shall not be located in any yard adjacent to a public street.
  - (b) Accessory buildings and structures shall be subject to all set back and “build-to” lines of the property.
  - (c) Accessory buildings and structures shall be designed and detailed to complement the primary buildings.

**B. Standards for Existing Buildings**

The Downtown Overlay District includes areas containing existing buildings, structures and amenities including homes, businesses, walls, fencing, lighting, sidewalks, drives, etc. These elements constructed prior to the implementation of the Downtown Overlay District shall be considered “existing buildings”. As such they may be exempted from some of the requirements of this article as detailed below.

- (1) Exemptions for Existing Buildings  
 Except as noted below, all existing buildings or portions thereof are exempted from the regulations in this section until such time that they are substantially renovated. Substantial renovation shall mean a major change involving more than 25 percent of the building. Any new portion of such building is subject to all regulations in the downtown overlay district design standards.
- (2) Renovation requirements
  - (a) All buildings, on being substantially renovated, shall conform to all of the downtown overlay district design standards unless otherwise approved by the Planning Commission except as follows.

- (b) Building and Structure Locations: The locations of existing buildings and site amenities including parking, curb-cuts, sidewalks, utilities, loading areas, and walls shall be considered grandfathered and will be exempt from the requirements of this article until such time when the original building is completely demolished.
- (3) Minor Changes and Repairs
  - (a) A minor repair using similar or like materials and colors does not require review. For example repainting in the same color, covering graffiti, replacing a single broken widow sash, repointing old brick, etc. do not require review.
  - (b) The following specific changes in the exterior finish require review and approval by the City Planner:
    - (i) Change in visible exterior surface finish materials (ex. stucco over brick)
    - (ii) Changes in exterior paint colors including trim
    - (iii) Changes in sets of windows
    - (iv) Changes in doors
    - (v) Changes in canopies or awnings
    - (vi) Changes in balconies, decks and porches

## 8 Sustainable Maintenance Requirements

Adequate ongoing maintenance is critical to the success of any built project. Without proper regular cleaning, maintenance and repairs to buildings, pavement, furnishings, and landscaping these elements can quickly become unsightly and even unsafe. Deferred maintenance can lead to unsightly conditions and have a substantial negative effect on the surrounding properties. Additionally, regular maintenance is part of any good sustainability program. Systems that provide returns to the users in the form of lower energy costs and reduced lifecycle costs require maintenance to keep them performing optimally.

Therefore the City requires that all owners maintain their properties in a clean and working condition. All areas of a property within the Downtown Overlay District visible from a public right-of-way are subject to the provisions of this section.

### A. All properties vacant or otherwise

- (1) All grassed areas shall be mowed regularly and no grass or weeds may be allowed to exceed 8" in height.
- (2) Leaves and debris from the regular maintenance of trees, shrubbery and grass must be removed from paved areas and lawns and properly disposed of or composted off site.
- (3) Fall leaves are to be removed from parking lots, sidewalks, plazas, and streets weekly during the leaf drop season to avoid the potential for damage that leaves may cause which include: clogged storm drains, dangerous pavement conditions and the creation of conditions favorable for fungus to develop in landscape areas.
- (4) Natural (wooded) areas shall be minimally maintained as follows:
  - (a) Dead and downed trees, hazardous (as determined by an ISA Certified Arborist) trees, and large dead branches shall be removed from the sites.
- (5) Obvious vandalism including graffiti and damaged furnishings shall be removed, repaired, and or painted over; graffiti shall be painted over with a color matching the predominant base color within 15 days of notice by the City.
- (6) Dumping: Any waste materials that have been dumped on a site shall be removed from the site within 15 days' notice from the City.
- (7) Site elements not required to be maintained by the City or utility company such as site furnishings, light fixtures, or other similar amenities that are visible from a public right-of-way and have been broken, vandalized, or severely damaged shall be either removed or

## EXHIBIT A

### Downtown Overlay District Design Standards

Version:

- repaired within 90 days of notice by the City.
- (8) Debris caused by storms, such as downed trees, limbs, roofing, etc. occurring in the front yard shall be removed from the site within ten business days.
  - (9) Fencing and walls, temporary or otherwise (excepting silt fence and tree protection fencing) shall not be allowed to fall into disrepair. Damaged, broken, leaning, rotten or otherwise unsightly fencing and walls must be repaired within 30 days' notice by the City.
- B. Vacant, cleared, and undeveloped lots**
- (1) All vacant, cleared, and undeveloped lots, which are not used for parking, shall be grassed and landscaped.
  - (2) No debris or stock piles of materials, other than stone, gravel, soil and brick reclaimed from the existing buildings and pavement, may be left on the site unless a land disturbance or construction permit has been issued. Any such stock piles stored on a site prior to issuance of a construction permit shall be adequately screened using fencing or other means so as not to be visible from an adjacent public right-of-way at typical eye level.
- C. Maintenance Standards for All Developed Property in the Overlay District**
- The maintenance of various street furnishings, pavements, structures, and landscapes is to be split between the City and the property owners. In an effort to correctly place responsibility for maintenance between the city and property owner, the following division of responsibility has been established.
- (1) Elements to be maintained by the City
    - (a) Street Trees or any trees – within the Public right-of-way
    - (b) Curb and Gutter - along public streets and within the Public right-of-way
    - (c) Public Signs
    - (d) Public Street paving within the Public right-of-way
    - (e) Public Crosswalks including pavers, striping and signals within the Public right-of-way
    - (f) Bus Stops
    - (g) Public On-Street Parking Areas and Striping within the Public right-of-way
    - (h) Public Trash Receptacles within the Public right-of-way
    - (i) Landscaping areas within the Public right-of-way between the street and sidewalk.
    - (j) Benches and street furniture within the Public right-of-way
    - (k) Sidewalks, pedestrian pavers, fencing and walls within the Public right-of-way
    - (l) Street, sidewalk and public lighting within the Public right-of-way
  - (2) Elements to be maintained by the property owner

The owner of each designated overlay district property or site, shall keep in good repair all of the exterior portions of such property and site and all interior portions thereof which, if not maintained, may cause or tend to cause the exterior portion of such property or site to deteriorate, decay or become damaged or otherwise to fall into a state of disrepair.

    - (a) The following are the responsibility of the property owner:
      - (i) Removing trash and ice from sidewalks fronting owner's property
      - (ii) Any building improvements
      - (iii) Awnings
      - (iv) Business and way-finding signs
      - (v) Lighting attached to the building or on the owner property.
      - (vi) All turf, lawn or grass including that which extends into the public right-of way between the owner's property and the sidewalk or street.
      - (vii) All woody landscaping other than that which lies in the Public right-of-way shall



EXHIBIT A

Downtown Overlay District  
Design Standards

Version:

- be maintained by the property owner of the abutting property.
- (viii) Potted plants or planters which the owner places between the Public right-of-way line and the public sidewalk's clear zone shall be maintained by the owner.
- (ix) All trees and shrubs planted on private property are the maintenance responsibility of the property owner.

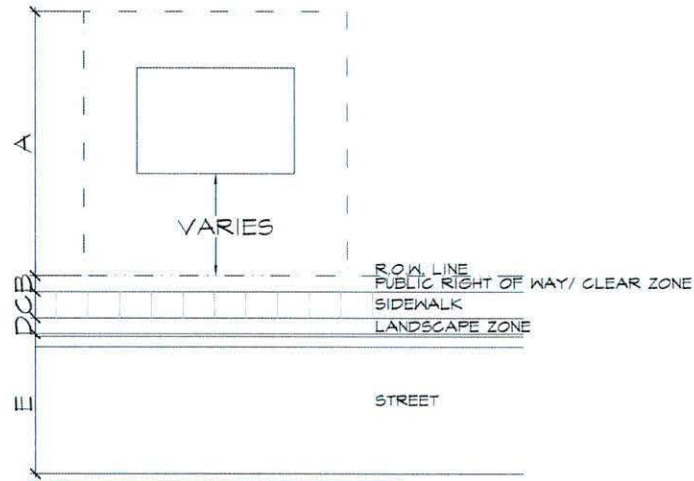

Figure 72 Maintenance Zones Diagram

ZONE	Responsible Party
A	Owner
B	City
C	City
D	City
E	City

EXHIBIT A

Downtown Overlay District  
Design Standards

Version:

Downtown Overlay District Map

