

Date of Action: 2/22/16	
Approved <input checked="" type="checkbox"/>	Denied <input type="checkbox"/>
By: <i>Jamellum</i>	

**CITY COUNCIL ACTION MEMORANDUM**

**AM No. 16-07: Awarding contract to Ferguson Enterprises, Inc. in the amount of \$48,189 for Sewer Effluent Pumps.**

Originator: April Dwyer, Purchasing Officer

Date: 2/2/2016

Agenda of: 2/22/2016

Route to:	Department Head	Signature	Date
	Chief of Police		
X	Public Works Director	<i>[Signature]</i>	2/9/16
	Recreation & Cultural Services Director		
X	Finance Director	<i>[Signature]</i>	2-9-16
X	Deputy Administrator	<i>[Signature]</i>	2/9/16
X	City Clerk	<i>[Signature]</i>	2/9/16

Reviewed by Mayor Bert L. Cottle: *[Signature]* 02:10:2016

**Fiscal Impact:**  yes or  no

**Funds Available:**  yes or  no

**Account name/number/amount:**

Sewer Utility – Supplies                      310.4353.435.60.99                      \$48,189

**Attachments:** ITB 0115-0-2015/AD Sewer Effluent Pumps (17 pages)

**Summary Statement:** On January 15, 2016 the City of Wasilla issued Invitation to Bid, ITB 0115-0-2016/AD for Sewer Effluent Pumps. Five bids were received and reviewed. The low bidder is Ferguson Enterprises, Inc. in the amount of \$48,189. It is recommended that the City purchase the Sewer Effluent Pumps from Ferguson Enterprises, Inc. This bid also includes the option to purchase additional pumps as needed within one-year from initial award date.

**Staff Recommendation:** Adopt AM No. 16-07 and award a one-year contract to Ferguson for Sewer Effluent Pumps.

# CITY OF WASILLA

• Purchasing •

290 East Herning Avenue • Wasilla • Alaska • 99654-7091

• Telephone 907-373-9047 • Fax 907-373-9046 •



*As specified  
Pumps.*

*Meyers Pump Quote*

## INVITATION TO BID

No. 0115-0-2016/AD

Sewer Effluent Pumps

RECEIVED

JAN 28 2016

CITY OF WASILLA  
Public Works Dept.

## RELEASE DATE

January 15, 2016

## SUBMISSION DEADLINE & BID OPENING TIME

February 1, 2016 @ 2pm

A company or individual that submits a bid MUST be on the official City of Wasilla planholders list which is maintained at:  
[http://www.demandstar.com/supplier/bids/agency\\_inc/bid\\_list.asp?f=search&mi=712050](http://www.demandstar.com/supplier/bids/agency_inc/bid_list.asp?f=search&mi=712050)

Failure to be on the list will be cause for their bid to be deemed non-responsive.

In addition, any copies of this bid, attachments or addendums obtained from any source other than [www.cityofwasilla.com/purchasing](http://www.cityofwasilla.com/purchasing) or the City of Wasilla Purchasing Officer are not valid.

For additional information, please contact:

April Dwyer, Purchasing Officer  
(907) 373-9047

**BID SUBMITTAL INFORMATION**

Bid Specifications & Signature Page located on pages 12 – 13.

This ITB contains a total of thirteen (13) pages.

Bids sent by mail or overnight delivery must be returned in a sealed envelope with the bid number and opening date clearly marked in the lower left corner on the front side of the envelope. Bids mailed by the US Postal Service, UPS, Federal Express, DHL, etc. must be addressed to: *CITY OF WASILLA, Purchasing Officer, 290 E. HERNING AVENUE, WASILLA, AK 99654*. The City of Wasilla will not be held responsible for bid envelopes mishandled as a result of the envelope not being properly prepared. Faxed bids will not be accepted. Bids sent by special mail (UPS, Overnight, Fed-Ex., etc.) that do not arrive by bid opening time and date **WILL NOT BE ACCEPTED**.

This entire document and any amendments if applicable to this bid must be returned as part of the contractor's bid submission. Contractors must return one (1) signed copy of their entire bid document submission to the Purchasing Officer prior to the close of this solicitation. Failure to comply with this requirement will be grounds for non-acceptance of the bid.

**BID PRICES WILL BE DISCLOSED AS REQUIRED BY WASILLA MUNICIPAL CODE. WHILE PRICE IS AN IMPORTANT CRITERIA CONSIDERATION IN THE BID AWARD PROCESS IT IS NOT THE ONLY CRITERIA. A BID AWARD IS MADE TO THE LOWEST RESPONSIBLE BIDDER OR BIDDERS BASED UPON AN EVALUATION OF ALL BIDS SUBMITTED AND THEIR CONFORMANCE WITH SPECIFICATIONS, TERMS AND CONDITIONS STATED IN THE BID. THE PURCHASING OFFICER MAY REJECT ANY OR ALL BIDS OR MAY ACCEPT THE BID DETERMINED BEST FOR THE INTEREST OF THE CITY.**

**1. ACRONYMS/DEFINITIONS:**

For the purposes of this Invitation to Bid, the following acronyms/definitions will be used:

Bidder	Company/vendor/individual submitting a bid in response to this Invitation to Bid.
City	The City of Wasilla and any City department identified herein.
Goods	Within the definition of WMC 5.08.010 and 5.08.110; identified in this Invitation to Bid.
Lowest Responsible Bidder/Contractor	The organization/individual that is awarded a contract or order for the goods identified in this Invitation to Bid.
May	Indicates something that is not mandatory but permissible.
Responsible	A bid and bidder will be determined responsible if s/he meets the following criteria: The skill/experience demonstrated by bidder in performing contracts of a similar nature. The bidder's record for honest and integrity. The bidder's capacity to perform in terms of facilities, personnel and financing. The bidder's past performance under city contracts.

Responsive	A bid and bidder that conforms in all material respects to the solicitation.
Shall/Must	Indicates a mandatory requirement. Failure to meet a mandatory requirement may result in the rejection of a bid as non-responsive.
WMC	Wasilla Municipal Code

2. **BID SOLICITATION, EVALUATION AND AWARD PROCESS:**

- a. This procurement is being conducted in accordance with WMC 5.08.110.
- b. For purposes of addressing questions concerning this Invitation to Bid, the sole contact will be the Purchasing Officer. Upon issuance of this Invitation to Bid, employees and representatives of the agencies identified herein will not answer questions or otherwise discuss the contents of this Invitation to Bid with any prospective bidders or their representatives. Failure to observe this restriction may result in disqualification of any bid. This restriction does not preclude discussions between affected parties for the purpose of conducting business unrelated to this procurement.
- c. Pursuant to WMC 5.08.110, responsible bids must conform to all standards and specifications in the Invitation to Bid.
- d. Pursuant to WMC 5.08.110, the Purchasing Division may enter into a contract using a standard form of contract, by advertising in accordance with the provisions of WMC 5.08.110(B) for the furnishing of goods and services for not more than 5 years. The original terms of a contract may be extended annually thereafter if the conditions for extension are specified in the original solicitation, and the Purchasing Officer determines that an extension is in the best interest of the city.
- e. In accordance with WMC 5.08.190, the city has a local contractor preference. WMC 5.08.190 states:
  - a. The city may specify in an invitation for bids or request for proposals that it will reduce the bid or proposal price of a local contractor by two and one-half (2-1/2) percent for purposes of bid or proposal evaluation.
  - b. If the city has specified that an invitation for bids or request for proposals is subject to the local contractor preference authorized by subsection A of this section, the city will reduce the price bid or proposed by each local contractor by two and one-half (2-1/2) percent before evaluating bid or proposal prices for purposes of contract award. The reduction authorized by this subsection is applied only for bid or proposal evaluation, and is not applied to the awarded contract price.
  - c. A local contractor is a person who:
    - i. Holds current State of Alaska, City of Wasilla and Matanuska-Susitna Borough business licenses;
    - ii. Submits a bid or proposal under the name which appears on its current State of Alaska, City of Wasilla and Matanuska-Susitna Borough business licenses; and
    - iii. Has maintained a place of business within the Wasilla City limits staffed by the contractor or an employee of the contractor for a period of at least six months immediately preceding the date of submission of the bid or proposal.
  - d. Pursuant to WMC 5.08.110 and 5.08.130, all goods with an the estimated cost in excess of \$10,000 must be purchased by formal contract from the lowest responsible bidder after due notice inviting the submission of sealed bids to the Purchasing Division at the date, hour and location set forth in the bid, and at that date, hour and location the bids must be publicly opened.



Bid No. ITB-0115-0-2016/AD

- e. Pursuant to WMC 5.08.110 and 5.08.170, the Purchasing Officer, Mayor and/or City Council may reject any or all bids, or may accept the bid determined best for the interest of the City.
- f. In awarding contracts for the purchase of goods and services, whenever two or more lowest bids are identical, the Purchasing Officer shall:
  - i. If the lowest bids are by bidders resident in the City of Wasilla, accept the bid that is in the best interests of the City.
  - ii. If the lowest bids are by bidders resident outside the City:
    - 1. Accept the bid for goods or commodities produced or manufactured in the State; or
    - 2. Accept the bid for goods or commodities supplied by a dealer resident in the State.
- g. All bids on more than one item on which bids are called for by the same notice must be itemized and give a price for each item.
- h. Pursuant to WMC 5.08.110 all bids must:
  - i. Be in writing and signed.
  - ii. Be sealed or, if the bid is submitted electronically, secured by an electronic equivalent of a seal, as approved by the Purchasing Officer.
  - iii. Be opened and read publicly by the Purchasing Officer as they are opened.
- i. Pursuant to WMC 5.08.160 every contract or order for goods and services must be awarded to the lowest responsible bidder. To determine the lowest responsible bidder, the Purchasing Officer shall consider, if applicable, the imposition of inverse preference described in WMC 5.08.190 and may consider:
  - i. The location of the using agency to be supplied.
  - ii. The qualities of the goods or services to be supplied.
  - iii. The total cost of ownership of the goods to be supplied.
  - iv. Except as otherwise provided in paragraph (5), the conformity of the goods or services to be supplied with the specifications.
  - v. If the goods or services are an alternative to the specifications listed in the original invitation for bids, whether the advertisement for bids included a statement that bids for an alternative article will be considered if:
    - 1. The specifications of the alternative goods or services meet or exceed the specifications of the article listed in the original invitation for bids;
    - 2. The purchase of the alternative goods or services results in a lower price; and
    - 3. The Purchasing Officer deems the purchase of the alternative goods or services to be in the best interest of the City of Wasilla.
  - vi. The purposes for which the goods or services to be supplied are required.
  - vii. The dates of delivery of the goods or services to be supplied.
- j. When determining the purchase of goods, the Purchasing Officer will consider the "total cost of ownership" which includes, but is not limited to:
  - i. The history of maintenance or repair of the goods;
  - ii. The cost of routine maintenance and repair of the goods;
  - iii. Any warranties provided in connection with the goods;
  - iv. The cost of replacement parts for the goods; and
  - v. The value of the goods as used goods when given in trade on a subsequent purchase.
- k. Pursuant to WMC 5.08.110(D.1.), the Purchasing Officer may allow a person to withdraw his bid if:

- i. The Purchasing Officer believes that an obvious error has been made by the person which would cause him financial hardship; and
- ii. The contract has not yet been awarded.
- l. Pursuant to WMC 5.08.110(E) each bid and the name of the person making the bid shall be entered on a record. The record, with the name of the successful bidder indicated thereon, shall be open to public inspection after the award of the contract.
- m. Reference to a specific manufacturer or a specific product or model in the bid specifications does not restrict bidders to that manufacturer, product or model. This method is used to indicate the functional requirements (e.g., type, design, characteristics, quality) of the article desired. Bids may be considered on other manufacturer's products or other models determined by the Purchasing Officer to be the functional equivalent of the product or model referenced.
- n. Submission of a bid shall constitute an agreement to all terms and conditions specified in the Invitation to Bid, including, without limitation, the Terms and Conditions for Purchase of Goods set forth in Section 4, except such terms and conditions that the bidder expressly excludes.
- o. Bids must include any and all proposed terms and conditions, including, without limitation, written warranties, maintenance/service agreements, license agreements, lease purchase agreements and the bidder's standard contract language. The omission of these documents renders a bid non-responsive. A review of these documents is necessary to a determination of which bid is in the best interests of the City.
- p. For any bid exceeding \$100,000 for total of all base items and alternates, the successful Bidder shall furnish the Purchasing Officer a Performance and Payment Bond in the full amount of the Agreement and shall maintain the Bond in force during the continuance of the Agreement including the one-year warranty period, unless otherwise specified. The Bond shall be for the faithful performance of the Agreement in all respects including, but not limited to, payments for all materials and labor. All alterations, extensions of time, additional work and other changes authorized by the Agreement Documents may be made without securing the consent of the Surety or Sureties. Power-of-Attorney for the person signing the Bond for the Surety must be submitted with the Bond.
- q. Prices offered in bids are an irrevocable offer for the term of the contract and any contract extensions unless otherwise specified.
- r. The Purchasing Officer's acceptance of a bid through a written Notification of Award will create a binding contract.
- s. Sanctions for breach of contract and penalties may be assessed by the Purchasing Officer.
- t. Tabulations of the bid evaluation are available to all bidders via Demandstar.com or by contacting the Purchasing Officer.
- u. Pursuant to WMC 5.16 any contractor who enters into a contract with the City of Wasilla and who sells tangible personal property in the City of Wasilla is required to obtain a permit and agree to collect and pay the taxes imposed by law on the sale of tangible personal property in this city.

3.

**TERMS AND CONDITIONS FOR PURCHASE OF GOODS AND/OR SERVICES:**

- a. **ASSENT:** The City and Contractor agree that the City's acceptance of Contractor's Bid through the issuance of a written Notification of Award shall create a binding Contract.
- b. **INCORPORATED DOCUMENTS:** The Contract shall consist of this Invitation to Bid and any amendments to this invitation to bid if applicable the Contractor's Bid and all documentation contained therein, and the Notification of Award, together with any subsequently-issued Purchase Order executed by a person with full power and authority to issue same on behalf of the City. A

Contractor's Bid shall not contradict or supersede any City specifications, terms or conditions without written evidence of mutual assent to such change appearing in this Contract.

- c. **DEFINITIONS:** "City" means the City of Wasilla and any city department identified herein.
- d. **CONTRACT TERM:** This Contract shall be effective for the period indicated in the Invitation to Bid, unless sooner terminated by either party as set forth in this Contract. The Contract term may be extended.
- e. **NOTICE:** All notices or other communications required or permitted to be given under this Contract shall be in writing and shall be deemed to have been duly given if delivered personally in hand, by telephonic facsimile with simultaneous regular mail, or mailed certified mail, return receipt requested, postage prepaid on the date posted, and addressed to the other party at the address set forth above.
- f. **TERMINATION:**
  - i. Without Cause. This Contract may be terminated upon written notice by mutual consent of both parties or by the City upon 5 days written notice without cause.
  - ii. City Termination for Nonappropriation. The continuation of this Contract beyond the current year is subject to and contingent upon sufficient funds being appropriated, budgeted, and otherwise made available by the Wasilla City Council and/or federal sources. The City may terminate this Contract, and Contractor waives any and all claim(s) for damages, effective immediately upon receipt of written notice (or any date specified therein) if for any reason the Contracting Agency's funding from City, State, and/or federal sources is not appropriated or is withdrawn, limited, or impaired.
  - iii. Cause Termination for Default or Breach. A default or breach may be declared with or without termination. This Contract may be terminated by either party upon written notice of default or breach to the other party as follows:
    - 1. If Contractor fails to provide or satisfactorily perform any of the conditions, work, deliverables, goods, or services called for by this Contract within the time requirements specified in this Contract or within any granted extension of those time requirements; or
    - 2. If any state, county, city or federal license, authorization, waiver, permit, qualification or certification required by statute, ordinance, law, or regulation to be held by Contractor to provide the goods or services required by this Contract is for any reason denied, revoked, debarred, excluded, terminated, suspended, lapsed, or not renewed; or
    - 3. If Contractor becomes insolvent, subject to receivership, or becomes voluntarily or involuntarily subject to the jurisdiction of the bankruptcy court; or
    - 4. If the City materially breaches any material duty under this Contract and any such breach impairs Contractor's ability to perform; or
    - 5. If it is found by the City that any quid pro quo or gratuities in the form of money, services, entertainment, gifts, or otherwise were offered or given by Contractor, or any agent or representative of Contractor, to any officer or employee of the City of Wasilla with a view toward securing a contract or securing favorable treatment with respect to awarding, extending, amending, or making any determination with respect to the performing of such contract; or
    - 6. If it is found by the City that Contractor has failed to disclose any material conflict of interest relative to the performance of this Contract.

7. Time to Correct. Termination upon a declared default or breach may be exercised only after service of formal written notice as specified in paragraph (5), and the subsequent failure of the defaulting party within 15 calendar days of receipt of that notice to provide evidence, satisfactory to the aggrieved party, showing that the declared default or breach has been corrected.
8. Winding Up Affairs Upon Termination. In the event of termination of this Contract for any reason, the parties agree that the provisions of this paragraph survive termination:
9. The parties shall account for and properly present to each other all claims for fees and expenses and pay those that are undisputed and otherwise not subject to set off under this Contract. Neither party may withhold performance of winding up provisions solely based on nonpayment of fees or expenses accrued up to the time of termination;
10. Contractor shall satisfactorily complete work in progress at the agreed rate (or a pro rata basis if necessary) if so requested by the Contracting Agency.

g. **REPRESENTATIONS:** Contractor represents and warrants to the City:

- i. **Contractor Authorization:** Contractor is duly organized, validly existing, and in good standing under the appropriate laws with full power and authority to conduct the business that it presently conducts in the City of Wasilla. Contractor has the legal power and right to enter into and perform the Contract. Consummation of the transactions contemplated by the Contract will not violate any provision of law, or any of Contractors governing documents (articles of incorporation, partnership Contract, etc). Execution of the Contract and all documents provided for in the Contract by Contractor and its delivery to the City have been duly authorized by the board of directors or managing agents of Contractor and no further action is necessary on Contractor's part to make the Contract valid and binding on Contractor in accordance with its terms. Contractor has obtained all licenses and permits to perform all of its requirements under the Contract, and is current on all tax obligations to the City of Wasilla or any other governmental entity in Alaska.
- ii. **Bid Representations:** All statements made by Contractor on any application, bid, proposal, offer, financial statement, or other document used by Contractor to induce the City to enter into the Contract are true, correct, complete, and omit no information which would render them misleading.

4. **BREACH; REMEDIES:** Failure of either party to perform any obligation of the Contract shall be deemed a breach. In the event of a breach, the party asserting breach may, in addition to any remedies or rights afforded by Alaska law, cancel the Contract with respect to any executory obligations. All rights and remedies are cumulative with one another and with those provided by law, and exercise of one remedy or right is not a waiver of the right to pursue any other right or remedy afforded. Penalties provided under Alaska law shall be limited to those in effect on the effective date of the Contract. Either party, as a prevailing party to any arbitration or other action regarding the enforcement of the Contract, is entitled to reasonable attorney fees and costs. It is specifically agreed that reasonable attorneys' fees shall include without limitation \$175 per hour for City-employed attorneys. The City may set off consideration against any unpaid obligation of Contractor to any City agency.
5. **LIMITED LIABILITY:** The City will not waive and intends to assert available liability limitations in all cases. Contract liability of both parties shall not be subject to punitive damages.
6. **WAIVER OF BREACH:** A failure to assert any right or remedy available to a party under this Contract, or a waiver of the rights or remedies available to a party by a course of dealing or otherwise

shall not be deemed to be a waiver of any other right or remedy under this Contract, unless such waiver is contained in a writing signed by the waiving party.

7. **SEVERABILITY:** If any provision contained in this Contract is held to be unenforceable by a court of law or equity, this Contract shall be construed as if such provision did not exist and the nonenforceability of such provision shall not be held to render any other provision or provisions of this Contract unenforceable.
8. **ASSIGNMENT/DELEGATION:** To the extent that any assignment of any right under this Contract changes the duty of either party, increases the burden or risk involved, impairs the chances of obtaining the performance of this Contract, attempts to operate as a novation, or includes a waiver or abrogation of any defense to payment by City, such offending portion of the assignment shall be void, and shall be a breach of this Contract. No duties of either party may be delegated without written consent by the other party, and any such consent does not in any way affect the liability of the delegating party, unless the writing so states.
9. **FORCE MAJEURE:** Contractor shall not be liable for any delay in delivery or failure to deliver any, or all of the goods where the delay or failure is caused by labor troubles, strikes, lockouts, war, riots, insurrection, civil commotion, failure of crops or supplies from ordinary sources, earthquake, fire, flood, storm, accident, any act of God or any other cause beyond the control of Contractor. City shall not be liable for failure to take delivery of the goods where any of the above causes prevent carrier or City from accepting delivery. But, in any case, the party claiming the benefit of this provision shall use due diligence to remove any such causes and to resume performance under this Contract as soon as is feasible. Performance by the other party shall be suspended and excused during the period of any such delay or failure and performance shall resume as soon as possible after removal of the excuse.
10. **GOVERNING LAW; JURISDICTION:** The laws of Alaska, including, without limitation, Alaska's Uniform Commercial Code in effect on the date of the Notification of Award, shall govern this Contract. The parties consent to the jurisdiction of the trial courts for the State of Alaska at Palmer, Alaska for enforcement of this Contract.
11. **ENTIRE AGREEMENT; CONFLICT WITH OTHER DOCUMENTS:** This Contract (including all incorporated attachments) is intended by the parties as the final expression of their agreement and is the complete and exclusive statement of the terms hereof. All prior agreements are superseded and excluded. Prices, quantities, dates, and places of deliveries and means of transportation may be fixed by attachments to this Contract. Except as previously stated, if any term in any incorporated attachment or in any Contractor's invoice contradicts or negates a term in this Contract, this Contract shall control. All amendments must be in writing signed by the parties.
12. **INSURANCE SCHEDULE:** Unless expressly waived by negotiation in writing by the City, Contractor, as an independent contractor and not an employee of the City, must carry policies of insurance in amounts specified in this Insurance Schedule and pay all taxes and fees incident hereunto. The City shall have no liability except as specifically provided in the Contract. The Contractor shall not commence work before:
  - a. Contractor has provided the required evidence of insurance to the Contracting Agency of the City, and
  - b. The City has approved the insurance policies provided by the Contractor.
  - c. Prior approval of the insurance policies by the City shall be a condition precedent to any payment of consideration under this Contract and the City's approval of any changes to insurance coverage during the course of performance shall constitute an ongoing condition subsequent this Contract. Any failure of the City to timely approve shall not constitute a waiver of the condition.
  - d. Insurance Coverage: The Contractor shall, at the Contractor's sole expense, procure, maintain and keep in force for the duration of the Contract the following insurance conforming to the minimum



- requirements specified below. Unless specifically specified herein or otherwise agreed to by the City, the required insurance shall be in effect prior to the commencement of work by the Contractor and shall continue in force as appropriate until the latter of:
- i. Final acceptance by the City of the completion of this Contract; or
  - ii. Such time as the insurance is no longer required by the City under the terms of this Contract.
- e. Any insurance or self-insurance available to the City shall be excess of and non-contributing with any insurance required from Contractor. Contractor's insurance policies shall apply on a primary basis. Until such time as the insurance is no longer required by the City, Contractor shall provide the City with renewal or replacement evidence of insurance no less than thirty (30) days before the expiration or replacement of the required insurance. If at any time during the period when insurance is required by the Contract, an insurer or surety shall fail to comply with the requirements of this Contract, as soon as Contractor has knowledge of any such failure, Contractor shall immediately notify the City and immediately replace such insurance or bond with an insurer meeting the requirements.
- f. Workers' Compensation and Employer's Liability Insurance
- i. Contractor shall provide proof of worker's compensation insurance as required of Alaska Administrative Code Title 8.
  - ii. Employer's Liability insurance with a minimum limit of:
    1. Bodily Injury by Accident - \$100,000 per each accident
    2. Bodily Injury by Disease - \$100,000 per each employee
    3. Bodily Injury by Disease - \$500,000 policy limit
  - iii. If this contract is for temporary or leased employees, an Alternate Employer endorsement must be attached to the Contractor's workers' compensation insurance policy.
- g. Commercial General Liability Insurance
- i. Minimum Limits required:
    1. \$2,000,000 General Aggregate
    2. \$1,000,000 Products & Completed Operations Aggregate
    3. \$1,000,000 Personal and Advertising Injury
    4. \$1,000,000 Each Occurrence
- h. Business Automobile Liability Insurance
- i. Minimum Limit required: \$1,000,000 Each Occurrence for bodily injury and property damage. Coverage shall be for "any auto" (including owned, non-owned and hired vehicles). The policy shall be written on ISO form CA 00 01 or a substitute providing equivalent liability coverage. If necessary, the policy shall be endorsed to provide contractual liability coverage.
- i. Professional Liability Insurance
- i. Minimum Limit required: \$1,000,000 Each Claim
  - ii. Retroactive date: Prior to commencement of the performance of the contract
  - iii. Discovery period: Three (3) years after termination date of contract.
  - iv. A certified copy of this policy may be required.
- j. Umbrella or Excess Liability Insurance
- i. May be used to achieve the above minimum liability limits.
  - ii. Shall be endorsed to city it is "As Broad as Primary Policy"
- k. General Requirements:
- i. Additional Insured: By endorsement to the general liability insurance policy evidenced by Contractor, The City of Wasilla, its officers, employees and immune contractors shall be named as additional insureds for all liability arising from the Contract.

- ii. Waiver of Subrogation: Each liability insurance policy shall provide for a waiver of subrogation as to additional insureds.
- iii. Cross-Liability: All required liability policies shall provide cross-liability coverage as would be achieved under the standard ISO separation of insureds clause.
- iv. Deductibles and Self-Insured Retentions: Insurance maintained by Contractor shall apply on a first dollar basis without application of a deductible or self-insured retention unless otherwise specifically agreed to by the City. Such approval shall not relieve Contractor from the obligation to pay any deductible or self-insured retention.
- l. Policy Cancellation: Except for ten days notice for non-payment of premium, each insurance policy shall be endorsed to state that; without twenty (20) days prior written notice to the City of Wasilla, c/o Purchasing/Contracting Officer, the policy shall not be canceled, non-renewed or coverage and /or limits reduced or materially altered, and shall provide that notices required by this paragraph shall be sent by certified mailed to the address shown below.
- m. Approved Insurer: Each insurance policy shall be:
  - i. Issued by insurance companies authorized to do business in the State of Alaska or eligible surplus lines insurers acceptable to the City and having agents in Alaska upon whom service of process may be made, and
  - ii. Currently rated by A.M. Best as "A-VII" or better.
- n. Evidence of Insurance: Prior to the start of any Work, Contractor must provide the following documents to the contracting City:
  - i. Certificate of Insurance: The Acord 25 Certificate of Insurance form or a form substantially similar must be submitted to the City to evidence the insurance policies and coverages required of Contractor.
  - ii. Additional Insured Endorsement: An Additional Insured Endorsement (CG20 10 or C20 26) signed by an authorized insurance company representative, must be submitted to the City to evidence the endorsement of the City as an additional insured per General Requirements, Subsection a above.
  - iii. Schedule of Underlying Insurance Policies: If Umbrella or Excess policy is evidenced to comply with minimum limits, a copy of the Underlyer Schedule from the Umbrella or Excess insurance policy may be required.
- o. Review and Approval: Documents specified above must be submitted for review and approval by the City prior to the commencement of work by Contractor. Neither approval by the City nor failure to disapprove the insurance furnished by Contractor shall relieve Contractor of Contractor's full responsibility to provide the insurance required by this Contract. Compliance with the insurance requirements of this Contract shall not limit the liability of Contractor or its sub-contractors, employees or agents to the City or others, and shall be in addition to and not in lieu of any other remedy available to the City under this Contract or otherwise. The City reserves the right to request and review a copy of any required insurance policy or endorsement to assure compliance with these requirements.
- p. Mail all required insurance documents to the Contracting Agency identified on page one of the contract. Address the required insurance documents as ATTN: PURCHASING OFFICER.
- q. COMPLIANCE WITH LEGAL OBLIGATIONS. Contractor shall procure and maintain for the duration of this Contract any city, borough, state or federal license, authorization, waiver, permit, qualification or certification required by statute, ordinance, law, or regulation to be held by Contractor to provide the goods or services required by this Contract. Contractor will be responsible to pay all taxes, assessments, fees, premiums, permits, and licenses required by law. Real property and personal

property taxes are the responsibility of Contractor. Contractor agrees to be responsible for payment of any such government obligations not paid by its subcontractors during performance of this Contract. The City may set-off against consideration due any delinquent government obligation.

12. **SPECIAL TERMS AND CONDITIONS:**

- a. Assistance for handicapped, blind or hearing-impaired persons who wish to attend the bid opening is available through prearrangement with the Purchasing Officer.
- b. Proof, satisfactory to the City, must be provided by Bidder to show that any alternate article is equal to, or exceeds the bid specifications in design and performance. Complete and detailed comparative documentation for equipment other than requested in this solicitation is **required** to be submitted with bid. Equivalent items may be subject to performance testing.
- c. Bidders are especially cautioned to **RECHECK BID PRICES FOR ERRORS** prior to submitting bid as changes in bid prices after opening date and hour of bid due to an error **WILL NOT BE PERMITTED OR ACCEPTED**. Bidder shall be required to furnish equipment at price or prices bid on or be penalized by removal from bidder's list for a period of one year.
- d. **For purposes of addressing questions concerning this Invitation to Bid, the sole contact will be the Purchasing Officer. Upon issuance of this Invitation to Bid, employees and representatives of the agencies identified herein will not answer questions or otherwise discuss the contents of this Invitation to Bid with any prospective bidders or their representatives. Failure to observe this restriction may result in disqualification of any bid. This restriction does not preclude discussions between affected parties for the purpose of conducting business unrelated to this procurement.**
- e. The City of Wasilla reserves the right to make multiple awards as a result of this solicitation. The award(s) will be made to the lowest responsive and responsible bidder(s) meeting the requirements of the solicitation. The City reserves the right to conduct any tests it may deem advisable and to make all evaluations. The City also reserves the right to reject any or all bids, in whole or in part, to waive informalities and to delete items prior to making the award, whenever it is deemed in the sole opinion of the City to be in its best interest.

SPECIFICATIONS FOR SEWER EFFLUENT PUMPS

The City of Wasilla is seeking to secure Sewer Effluent Pumps for the Department of Public Works –Waste Water Division. Deliveries are to be FOB Wasilla. The final destination of all pumps ordered will be the City of Wasilla Sewer Plant located at 2900 Jude Street, Wasilla, Alaska 99654.

*Twenty (20) each - 240 volt single-phase, double-sealed, continuous run submersible effluent pumps capable of delivering 10 gallons per minute at a total dynamic head of 72 feet, 1-1/2" Discharge, 20' cord minimum. The pumps shall be specifically designed for pumping septic tank effluent and shall utilize corrosion-resistant materials of construction throughout, such as bronze and type 316 stainless steel components. Example of past approved pumps, Meyers P-52 or equal.*

*PLUS – Option to purchase an additional thirty (30) pumps, in incremental sales of ten (10), within one (1) year from the initial award date. \**

Cost per pump as described above, FOB Wasilla: \$ 601.95

Total for 20 pumps: \$ 12,039.00

*Sixty (60) each - 240 volt single-phase, double-sealed, continuous run submersible effluent pumps capable of delivering 10 gallons per minute at a total dynamic head of 102 feet, 1-1/2" Discharge, 20' cord minimum. The pumps shall be specifically designed for pumping septic tank effluent and shall utilize corrosion-resistant materials of construction throughout, such as bronze and type 316 stainless steel components. Example of past approved pumps, Meyers P-102 or equal.*

*PLUS – Option to purchase an additional sixty (60) pumps, in incremental sales of twenty (20), within one (1) year from the initial award date. \**

Cost per pump as described above, FOB Wasilla: \$ 602.50

Total for 60 pumps \$ 36,150.00

Total Bid Price: \$ 48,189.00

\* Additional pumps would need to be ordered in a quantity to meet our FFA requirement to Seattle.

This pricing information is hereby provided in accordance with the terms and conditions of this Invitation to Bid. I have read, understand, and agree to all terms and conditions herein.

Company Name: Ferguson Enterprises INC.

Contact Name: STEPHEN CAVERLY E-Mail Address: STEPHEN.CAVERLY@Ferguson.com

Address: 1977 E. Bogard Rd

City: Wasilla State: AK Zip: 99654

Telephone (907) 273-2158 Fax (907) 273-2115

Federal Tax ID No.: 54-1211721

Payment Terms NET 10<sup>th</sup> POX

Signed 

Print Name & Title STEPHEN CAVERLY - Sales Manager

Date 6/26/2016

I have read, understand and agree to comply with the terms and conditions specified in this Invitation to Bid. Checking "YES" indicates acceptance, while checking "NO" denotes non-acceptance and should be detailed below. Any exceptions must be documented.

YES  NO  SIGNATURE 

EXCEPTIONS: Attached additional sheets if necessary.  
\_\_\_\_\_  
\_\_\_\_\_  
\_\_\_\_\_  
\_\_\_\_\_  
\_\_\_\_\_



EFFLUENT PUMPING

# MYERS® P50 & P100 SERIES

The Myers® P series effluent pumps are designed specifically for multi-pump pressure collection, septic tank effluent pumping (S.T.E.P.) and high head drainage applications. The high efficiency, single-vane, enclosed impellers provide steep, non-overloading performance curves, which are ideal for these applications. These pumps deliver more capacity at higher heads than most pumps in this class. The combination of the most rugged materials ensure years of trouble-free, dependable service.

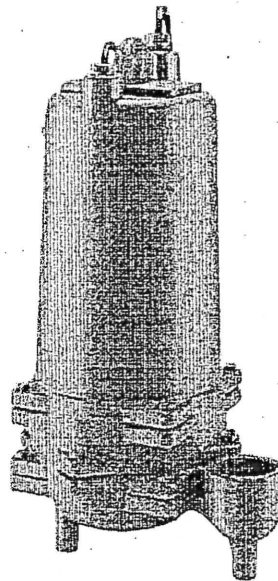

EFFLUENT PUMPING

Effluent removal, sump drainage, water transfer, flood control

EFFLUENT PUMPING

**Capacities** – Up to 60 GPM (227 LPM)  
**Shut-off Head** – Up to 124' (37.8 m)  
**Max. Spherical Solids** – 3/4" (19 mm)  
**Liquids Handling** – Domestic, effluent and drain water  
**Intermittent Liquid Temperature** – Up to 140°F (60°C)  
**Motor/Electrical Data** – 1/2 HP, 115V or 230V, 1Ø; 1 HP, 230V, 1Ø, oil-filled, permanent split capacitor type, 3450 RPM, 60Hz  
**Acceptable pH Range** – 6-9  
**Specific Gravity** – .9-1.1  
**Viscosity** – 28-35 SSU  
**Discharge, NPT** – 1-1/2" (38 mm)  
**Housing** – Cast iron  
**Minimum Sump Diameter** – Simplex: 24" (61 cm); Duplex: 36" (91.4 cm)  
**Power Cord** – 20', 14/3 SJOW, SJOW-A

EFFLUENT PUMPING

#### Rugged and Dependable

Durable, oil-filled motor for continuous bearing lubrication and maximum heat dissipation

#### Design Meets Demand

Single-vane, enclosed impeller provides steep, non-overloading performance curves for pressure collection and S.T.E.P. applications

#### Closed Case

Enclosed impeller eliminates jamming between impeller and volute – engineered thermoplastic composition

#### Powerful Starts

High-torque, permanent split capacitor (PSC) motor; no starting switches or relays to wear out

#### No Burnout

On-winding current and temperature sensitive overload to protect against costly burnout

#### Thermal Failsafe

Heat sensor overload protection with automatic reset when motor cools to a safe operating temperature

#### Twice the Protection

Optional leak probe senses water leakage past seal (dual seal motors only)

#### Restore Performance

Original performance standards can be restored by easily replacing a worn volute seal ring

**PERFORMANCE DATA**

# MYERS® P50 & P100 SERIES

**PERFORMANCE DATA**

Catalog Number	HP	Volts	Phase/Cycles	Discharge Size	Switch Type	Cord Length	Approx. Wt. Lbs.
P51	1/2	115	1/60	1-1/2"	Manual	20'	84
P51D	1/2	115	1/60	1-1/2"	Manual	20'	84
P52	1/2	230	1/60	1-1/2"	Manual	20'	84
P52D	1/2	230	1/60	1-1/2"	Manual	20'	84
P102	1	230	1/60	1-1/2"	Manual	20'	87
P102D	1	230	1/60	1-1/2"	Manual	20'	87



**DIMENSIONS**

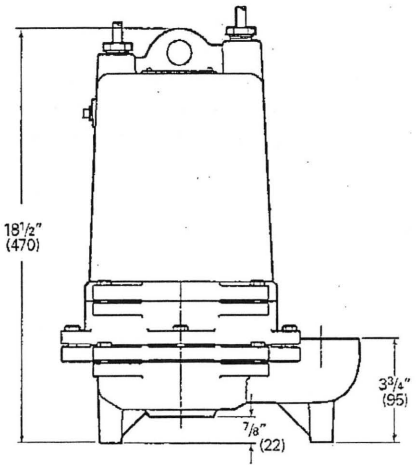
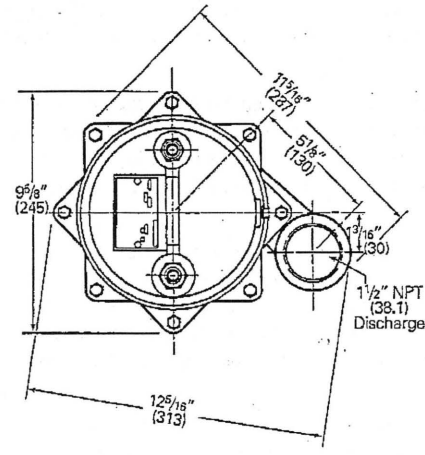

**PERFORMANCE DATA**

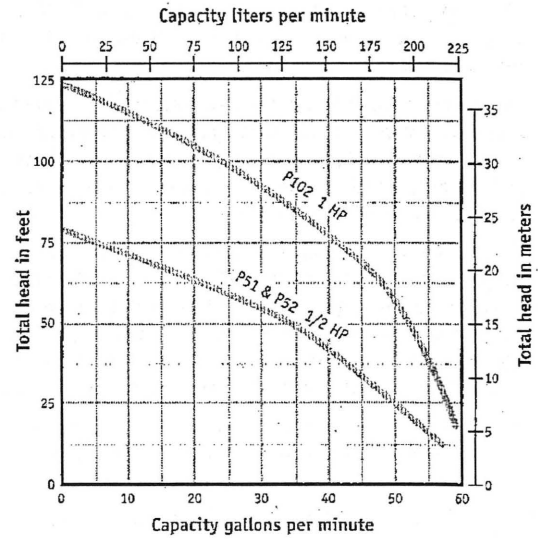

# MYERS® P50 & P100 SERIES

**Effluent Pumps** – Pump(s) shall be F. E. Myers model P series effluent pumps selected in accordance with the following design criteria:

Number of Pumps:	_____
Primary Design Flow:	_____
Primary Design Head:	_____
Minimum Shut-off Head:	80': (P51/P52) 124': (P102)
Motor Horsepower:	.5: (P51/P52) 1: (P102)
Motor Speed:	3450 RPM
Electrical:	P51: 115V, 1Ø P52/P102: 230V, 1Ø

**Pump** – The pump shall be designed to handle septic tank effluent and be capable of passing 3/4 inch spherical solids. The pump shall be capable of handling liquids with temperatures to 140°F intermittent and shall be capable of running dry without damage to the seals or bearings.

**Motor** – The pump motor shall be of the submersible type. Single phase motors shall be of the permanent split capacitor type with no relays or starting switches. Stator winding shall be of the open type with Class B insulation rated for 130°C maximum operating temperature. The winding housing will be filled with clean dielectric oil to lubricate bearings, seals, and transfer heat from the windings to the outer shell. The motor assembly shall be of the standard frame design and shall be secured in place by four threaded fasteners allowing for easy field serviceability.

The motor shall be capable of operating over the full range of the performance curve without overloading the motor and causing any objectionable noise or vibration. The motor shall have two bearings to support the rotor; an upper ball bearing to accommodate radial loads and a lower ball bearing to take thrust and radial loads. Ball bearings shall be designed for a B-10 life of 50,000 hours. A heat sensor thermostat and overload shall be attached to the top end of the motor windings and shall be wired in series with the windings to stop the motor if the motor winding temperature reaches 266°F. The overload thermostat shall reset automatically when the motor cools to a safe operating temperature.

**Power Cord** – The motor power cord shall be 14-3 SJOW/SJOWA or SOOW. The cable jacket shall be sealed at the motor entrance by means of a rubber compression washer and compression nut. A heat shrink tube filled with epoxy shall seal the outer cable jacket and the individual leads to prevent water from entering the motor housing.

**Seal Chamber** – The motor shall be protected by two (2) rotary shaft seals mounted in tandem with an oil filled chamber separating the seals. The seals shall have carbon and ceramic seal faces diamond lapped to a tolerance of one light band. Metal parts and springs for seals shall be 300 series stainless steel. Two optional electrical sensing probes shall be mounted in the seal chamber to detect any water leakage past the lower seal. The sensing probes shall be connected to a red warning light in the control panel. The warning light shall serve to indicate a seal leak and shall not stop the pump.

**Pump Impeller** – The pump impeller shall be of the single vane enclosed type. The impeller shall be constructed of an engineered thermoplastic. A stainless steel wear ring shall be molded into the neck of the thermoplastic impeller to provide a sealing surface. A replaceable Buna-N sealing cup shall effect a seal between the volute and impeller in order to maintain high efficiency and prevent recirculation. The impeller shall be threaded onto the 416 stainless steel pump/motor shaft.

**Pump and Motor Castings** – All casting shall be of high tensile strength Class 30 gray cast iron. Castings shall be treated with phosphate and chromate rinse and painted with a high quality air dry alkylid enamel.

**Fasteners** – All exposed fasteners shall be of 300 series stainless steel.



# MYERS® P50 & P100 SERIES



USA  
293 WRIGHT STREET, DELAVAN, WI 53115 [WWW.FEMEYERS.COM](http://WWW.FEMEYERS.COM)  
PH: 888-987-8677 ORDERS FAX: 800-426-9446

CANADA  
269 TRILLIUM DRIVE, KITCHENER, ONTARIO, CANADA N2G 4W5  
PH: 519-806-5484 ORDERS FAX: 800-426-9446

Because we are continuously improving our products and services, Pentair reserves the right to change specifications without prior notice.